

Brushless Flat DC-Micromotors

penny-motor® Technology

0,16 mNm

For combination with
Drive Electronics:
Speed controller with adapter board

Series 1202 ... BH

	1202 H	004 BH	006 BH	
Nominal voltage	U_N	4	6	V
Terminal resistance, phase-phase	R	16	70	Ω
Output power ¹⁾	$P_{2 \text{ max.}}$	0,652	0,492	W
Efficiency	$\eta_{\text{ max.}}$	51	42	%
No-load speed	n_0	41 740	37 600	rpm
No-load current	I_0	0,028	0,015	A
Stall torque	M_H	0,222	0,124	mNm
Friction torque, static	C_0	0,003	0,003	mNm
Friction torque, dynamic	C_v	$0,52 \cdot 10^{-6}$	$0,52 \cdot 10^{-6}$	mNm/rpm
Speed constant	k_n	10 587	6 431	rpm/V
Back-EMF constant	k_E	0,094	0,156	mV/rpm
Torque constant	k_M	0,902	1,485	mNm/A
Current constant	k_I	1,109	0,673	A/mNm
Slope of n-M curve	$\Delta n / \Delta M$	187 793	303 121	rpm/mNm
Terminal inductance, phase-phase	L	26	58	μH
Mechanical time constant	τ_m	246	397	ms
Rotor inertia	J	0,125	0,125	gcm^2
Angular acceleration	$\alpha_{\text{ max.}}$	$18 \cdot 10^3$	$10 \cdot 10^3$	rad/s^2
Thermal resistance	$R_{\text{th} 1} / R_{\text{th} 2}$	0 / 94		K/W
Operating temperature range		-30 ... +85		$^{\circ}\text{C}$
Shaft bearing		ball bearing		
Shaft load max.:				
– radial at 10 000 rpm (at shaft step $\varnothing 3,4$ mm)		0,6		N
– axial at 10 000 rpm (axial push-on only)		1		N
– axial at standstill (axial push-on only)		1		N
Shaft play:				
– radial	\leq	0,011		mm
– axial	\leq	0,060		mm
Number of pole pairs		4		
Weight		1,1		g
Direction of rotation		electronically reversible		
Recommended values - mathematically independent of each other				
Speed up to	$n_{e \text{ max.}}$	40 000	40 000	rpm
Torque up to ^{2) 3)}	$M_{e \text{ max.}}$	0,16	0,12	mNm
Thermal current up to ^{3) 4)}	$I_{e \text{ max.}}$	0,199	0,095	A

¹⁾ at 40 000 rpm ²⁾ at 10 000 rpm ³⁾ thermal resistance $R_{\text{th} 2}$ not reduced ⁴⁾ at standstill

 Scale enlarged

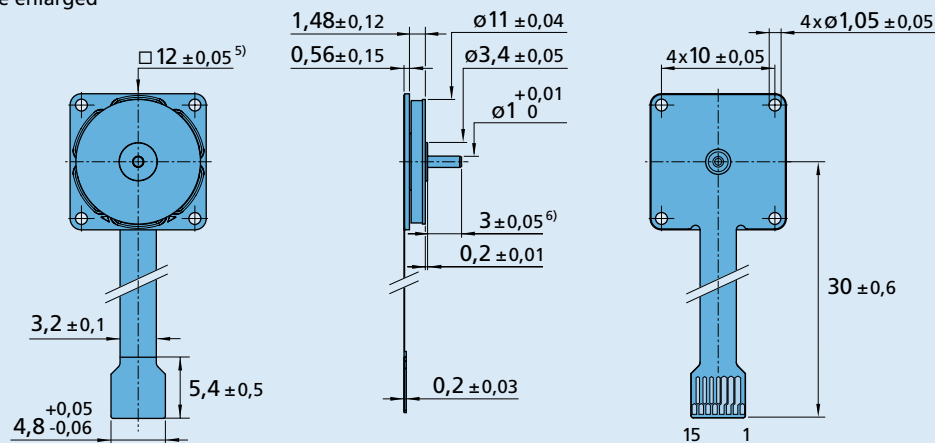

1202 H

Connection

No.	Function
1	Star point
2	Phase A
3	Phase A
4	Phase B
5	Phase B
6	Phase C
7	Phase C
8	Hall sensor In +
9	Hall sensor In -
10	analog Hall A Out +
11	analog Hall A Out -
12	analog Hall B Out +
13	analog Hall B Out -
14	analog Hall C Out +
15	analog Hall C Out -

Connectors

15-pole; 0,3 mm pitch; e.g.: Hirose: FH23-15S-0.3SHAW (05)