

Brushless DC-Motors

with integrated Drive Electronics

1,8 mNm

Series 1525 ... BRC

	1525 U	009 BRC	012 BRC	015 BRC	
Nominal voltage	U_N	9	12	15	Volt
No-load speed	n_0	16 300	15 800	15 500	rpm
No-load current (with shaft \varnothing 2,0 mm)	I_0	0,047	0,037	0,033	A
Starting torque	M_A	3,9	4,1	4,1	mNm
Torque constant	k_M	5,12	7,06	8,95	mNm/A
Slope of n-M curve	$\Delta n/\Delta M$	2 540	2 260	2 270	rpm/mNm
Rotor inertia	J	2,2	2,2	2,2	gcm ²
Operating temperature range		- 25 ... + 85			°C
Shaft bearings		ball bearings, preloaded			
Shaft load max.:					
- shaft diameter		2,0			mm
- radial at 3 000 rpm (3 mm from mounting face)		8			N
- axial at 3 000 rpm		0,8			N
- axial at standstill		10			N
Shaft play:					
- radial	\perp	0,015			mm
- axial	\parallel	0			mm
Housing material		mounting face in aluminium, housing in plastic			
Weight		16			g
Direction of rotation		reversible			

Recommended values - mathematically independent of each other

Speed range	n_e	1 000 - 16 000			rpm
Torque up to ¹⁾	$M_{e \max.}$	1,7	1,8	1,8	mNm
Current up to (thermal limits) ¹⁾	$I_{e \max.}$	0,40	0,31	0,25	A

¹⁾ Specification applies to $U_{\text{nsoll}} = 10 \text{ V}$

Electronic

Supply voltage	U_p	min. 4 ... max. 18		V DC
Current	$I_{\max.}$	15		mA

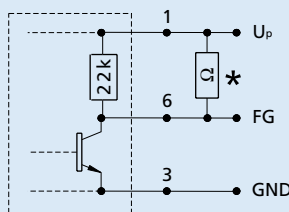

Circuit diagram

* An additional external pull-up resistor can be added to improve the rise time.

Caution:

$I_{\text{out max.}}$ 15 mA must not be exceeded!

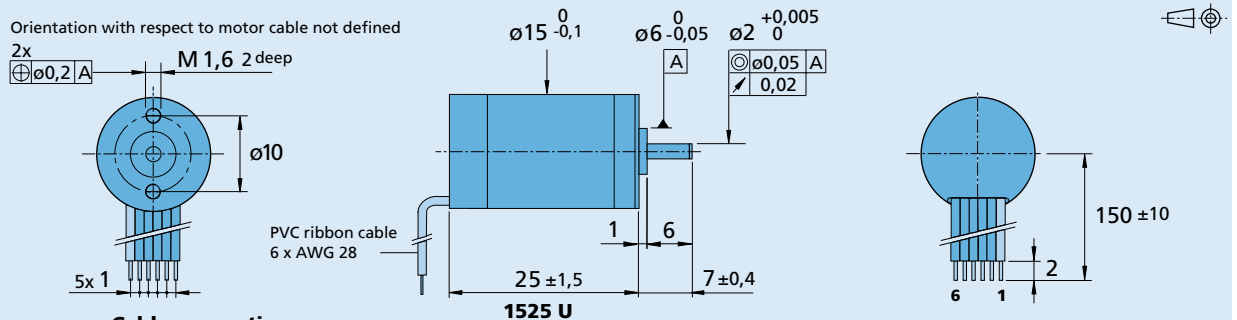

Cable connection

No.	Function	
1 (red)	U_p : electronic supply	4 V DC - 18 V DC
2	U_{mot} : coil supply	1,7 V DC - 18 V DC
3	GND : ground	
4	U_{nsoll} : Speed command	0 - 10 V DC > 10 V DC - max. U_p not defined
5	DIR : direction of rotation	on ground or $U < 0,5 \text{ V} = \text{CCW}$, $U > 3 \text{ V} = \text{CW}$
6	FG : frequency output	(max. U_p , $I_{\max.}$ 15 mA) 3 lines per revolution

Caution:

Incorrect lead connection will damage the motor electronics!