

# Brushless DC-Servomotors

## 4 Pole Technology

### 37 mNm

For combination with  
 Gearheads:  
 22F, 22/7, 26A  
 Encoders:  
 2250...BX4 + Encoder  
 Drive Electronics:  
 Speed Controller

### Series 2250 ... BX4

	2250 S		024 BX4		
1 Nominal voltage	$U_N$		24		Volt
2 Terminal resistance, phase-phase	R		5,9		$\Omega$
3 Output power <sup>1)</sup>	$P_{2 \text{ max.}}$		14,6		W
4 Efficiency	$\eta_{\text{ max.}}$		75,0		%
5 No-load speed	$n_0$		6 000		rpm
6 No-load current (with shaft $\varnothing$ 3,0 mm)	$I_0$		0,072		A
7 Stall torque	$M_H$		149,0		mNm
8 Friction torque, static	$C_0$		1,20		mNm
9 Friction torque, dynamic	$C_v$		$2,4 \cdot 10^{-4}$		mNm/rpm
10 Speed constant	$k_n$		259		rpm/V
11 Back-EMF constant	$k_E$		3,860		mV/rpm
12 Torque constant	$k_M$		36,9		mNm/A
13 Current constant	$k_I$		0,027		A/mNm
14 Slope of n-M curve	$\Delta n / \Delta M$		41,4		rpm/mNm
15 Terminal inductance, phase-phase	L		240		$\mu\text{H}$
16 Mechanical time constant	$\tau_m$		4,30		ms
17 Rotor inertia	J		10,0		$\text{gcm}^2$
18 Angular acceleration	$\alpha_{\text{ max.}}$		149		$\cdot 10^3 \text{ rad/s}^2$
19 Thermal resistance	$R_{\text{th} 1} / R_{\text{th} 2}$	1,2 / 14			K/W
20 Thermal time constant	$\tau_{w1} / \tau_{w2}$	4,2 / 566			s
21 Operating temperature range		- 40 ... + 100			$^{\circ}\text{C}$
22 Shaft bearings		ball bearings, preloaded			
23 Shaft load max.:					
– radial at 3 000 rpm (4 mm from mounting flange)		20			N
– axial at 3 000 rpm		2			N
– axial at standstill		20			N
24 Shaft play:					
– radial	$\leq$	0,015			mm
– axial	$=$	0			mm
25 Housing material		stainless steel			
26 Weight		106			g
27 Direction of rotation		electronically reversible			
28 Number of pole pairs		2			
<b>Recommended values - mathematically independent of each other</b>					
29 Speed up to	$n_{e \text{ max.}}$		18 000		rpm
30 Torque up to <sup>1) 2)</sup>	$M_{e \text{ max.}}$		23 / 37		mNm
31 Current up to <sup>1) 2)</sup>	$I_{e \text{ max.}}$		0,74 / 1,18		A

<sup>1)</sup> at 5 000 rpm

<sup>2)</sup> thermal resistance  $R_{\text{th} 2}$  not reduced / thermal resistance  $R_{\text{th} 2}$  by 55% reduced

#### Note:

The diagram indicates the recommended speed in relation to the available torque at the output shaft for a given ambient temperature of 22°C.

The diagram shows the motor in a completely insulated as well as thermally coupled condition ( $R_{\text{th} 2}$  55% reduced).

The nominal voltage ( $U_N$ ) curve shows the operating point at nominal voltage in the insulated and thermally coupled condition. Any points of operation above the curve at nominal voltage will require a higher operating voltage. Any points below the nominal voltage curve will require less voltage.

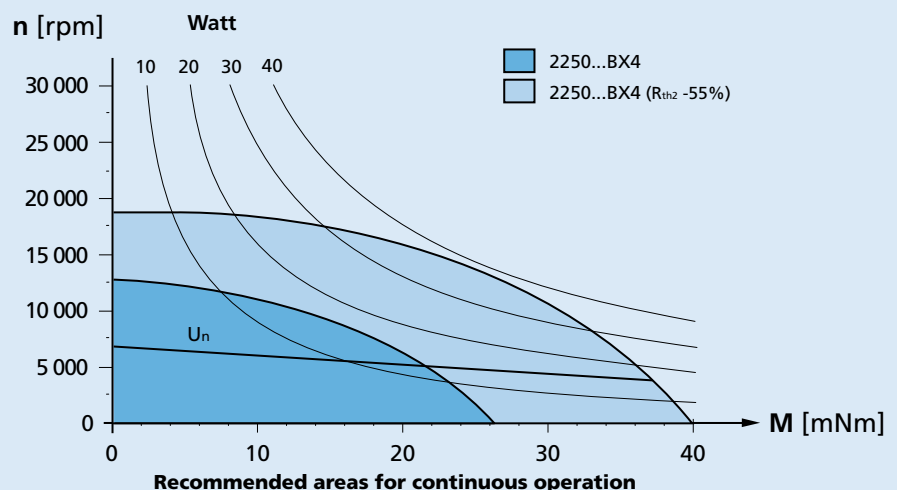

**Dimensional drawing**

M 1:1

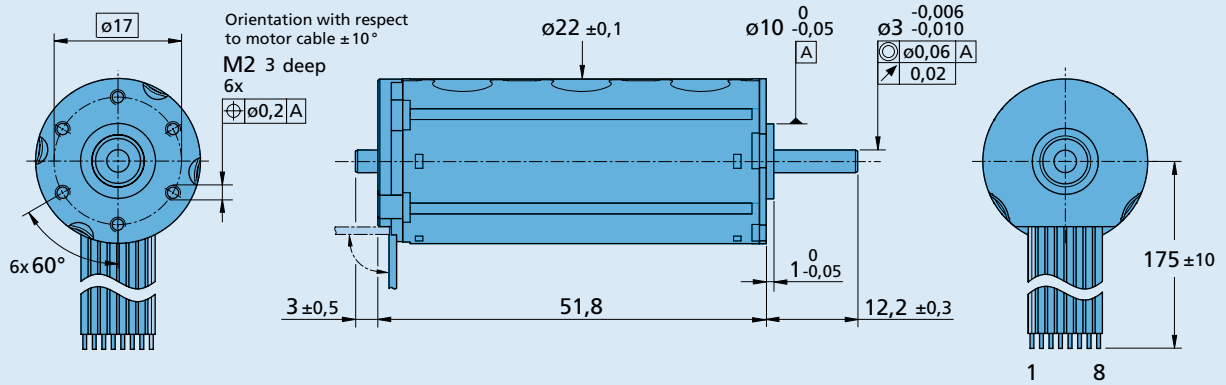

**2250 S ... BX4**

**Options**

- Connector variant (Option no. 3830)

**Motor:**  
AWG 26 / PVC ribbon cable  
with connector Micro-Fit

- Analog Hall sensors (Option no. 3692)



**Full product description**

- Examples:  
2250S024 BX4

**Cable and connection information**

