

# Brushless DC-Motors

with integrated Drive Electronics

28 mNm

## Series 3153 ... BRC

	3153 K	009 BRC	012 BRC	024 BRC	
Nominal voltage	$U_N$	9	12	24	Volt
No-load speed	$n_0$	5 200	5 200	5 200	rpm
No-load current (with shaft $\varnothing$ 4,0 mm)	$I_0$	0,142	0,107	0,057	A
Starting torque	$M_A$	42	50	50	mNm
Torque constant	$k_M$	16,22	21,80	43,59	mNm/A
Slope of n-M curve	$\Delta n/\Delta M$	45,8	42,9	41,4	rpm/mNm
Rotor inertia	J	118	118	118	gcm <sup>2</sup>
Operating temperature range		- 25 ... + 85			°C
Shaft bearings		ball bearings, preloaded			
Shaft load max.:					
- shaft diameter		4,0			mm
- radial at 3 000 rpm (3 mm from mounting face)		30			N
- axial at 3 000 rpm		5			N
- axial at standstill		50			N
Shaft play:					
- radial	$\leq$	0,015			mm
- axial	$\parallel$	0			mm
Housing material		mounting face in aluminium, housing in plastic			
Weight		155			g
Direction of rotation		reversible			

### Recommended values - mathematically independent of each other

Speed range	$n_e$		1 000 - 6 500		rpm
Torque up to <sup>1)</sup>	$M_{e \max.}$	27	28	28	mNm
Current up to (thermal limits) <sup>1)</sup>	$I_{e \max.}$	1,90	1,46	0,75	A

<sup>1)</sup> Specification applies to  $U_{nsoll} = 10$  V

### Electronic

Supply voltage	$U_p$	min. 5 ... max. 30	V DC
Current	$I_{\max.}$	25	mA

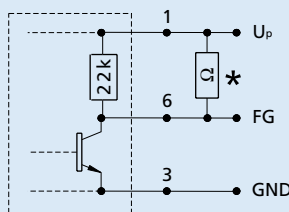

#### Circuit diagram

\* An additional external pull-up resistor can be added to improve the rise time.

#### Caution:

$I_{out \max.}$  15 mA must not be exceeded!

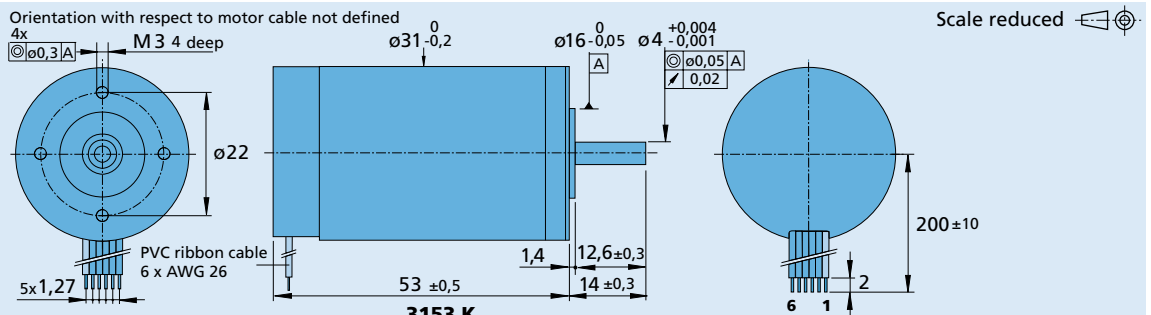

#### Cable connection

No.	Function	
1 (red)	$U_p$ : electronic supply	5 V DC - 30 V DC
2	$U_{mot}$ : coil supply	0 V DC up to $2 \cdot U_N$ (max. 30 V DC)
3	GND : ground	
4	$U_{nsoll}$ : Speed command	0 - 10 V DC   > 10 V DC - max. $U_p$ not defined
5	DIR : direction of rotation	on ground or $U < 0,5$ V = CCW, $U > 3$ V = CW
6	FG : frequency output	(max. $U_p$ , $I_{\max.}$ 15 mA) 3 lines per revolution

#### Caution:

Incorrect lead connection will damage the motor electronics!