

# Brushless DC-Servomotors

## 4 Pole Technology

# 97 mNm

**For combination with**  
 Gearheads:  
 30/1(S), 32A, 32ALN, 32/3(S), 38/1(S), 38/2(S)  
 Encoders:  
 3268...BX4 + Encoder  
 Drive Electronics:  
 Speed Controller

### Series 3268 ... BX4

	3268 G		024 BX4		
1 Nominal voltage	$U_N$		24		Volt
2 Terminal resistance, phase-phase	R		1,45		$\Omega$
3 Output power <sup>1)</sup>	$P_{2 \text{ max.}}$		35,8		W
4 Efficiency	$\eta_{\text{ max.}}$		79,5		%
5 No-load speed	$n_0$		5 500		rpm
6 No-load current	$I_0$		0,212		A
7 Stall torque	$M_H$		718		mNm
8 Friction torque, static	$C_0$		1,7		mNm
9 Friction torque, dynamic	$C_v$		$1,3 \cdot 10^{-3}$		mNm/rpm
10 Speed constant	$k_n$		220		rpm/V
11 Back-EMF constant	$k_E$		4,555		mV/rpm
12 Torque constant	$k_M$		43,5		mNm/A
13 Current constant	$k_I$		0,0230		A/mNm
14 Slope of n-M curve	$\Delta n / \Delta M$		7,3		rpm/mNm
15 Terminal inductance, phase-phase	L		110		$\mu\text{H}$
16 Mechanical time constant	$\tau_m$		4,6		ms
17 Rotor inertia	J		60		$\text{gcm}^2$
18 Angular acceleration	$\alpha_{\text{ max.}}$		120		$\cdot 10^3 \text{ rad/s}^2$
19 Thermal resistance	$R_{\text{th} 1} / R_{\text{th} 2}$	1,9 / 8,6			K/W
20 Thermal time constant	$\tau_{w1} / \tau_{w2}$	17 / 950			s
21 Operating temperature range		- 40 ... + 100			$^{\circ}\text{C}$
22 Shaft bearings		ball bearings, preloaded			
23 Shaft load max.:					
- radial at 3 000 rpm (4,5 mm from mounting flange)		50			N
- axial at 3 000 rpm		5			N
- axial at standstill		50			N
24 Shaft play:					
- radial	$\leq$	0,015			mm
- axial	$=$	0			mm
25 Housing material		stainless steel			
26 Weight		290			g
27 Direction of rotation		electronically reversible			
28 Number of pole pairs		2			
<b>Recommended values - mathematically independent of each other</b>					
29 Speed up to	$n_{e \text{ max.}}$		12 000		rpm
30 Torque up to <sup>1) 2)</sup>	$M_{e \text{ max.}}$		54 / 97		mNm
31 Current up to <sup>1) 2)</sup>	$I_{e \text{ max.}}$		1,57 / 2,72		A

<sup>1)</sup> at 5 000 rpm

<sup>2)</sup> thermal resistance  $R_{\text{th} 2}$  not reduced / thermal resistance  $R_{\text{th} 2}$  by 55% reduced

#### Note:

The diagram indicates the recommended speed in relation to the available torque at the output shaft for a given ambient temperature of 22°C.

The diagram shows the motor in a completely insulated as well as thermally coupled condition ( $R_{\text{th} 2}$  55% reduced).

The nominal voltage ( $U_N$ ) curve shows the operating point at nominal voltage in the insulated and thermally coupled condition. Any points of operation above the curve at nominal voltage will require a higher operating voltage. Any points below the nominal voltage curve will require less voltage.

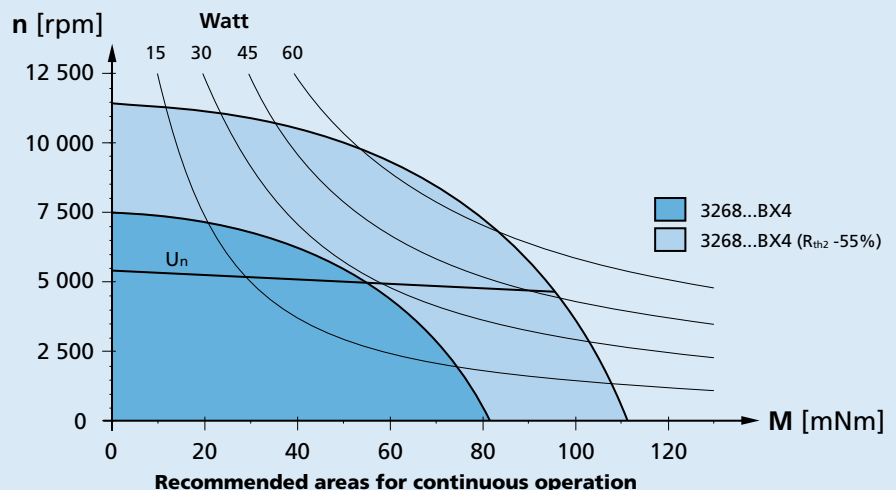

### Dimensional drawing

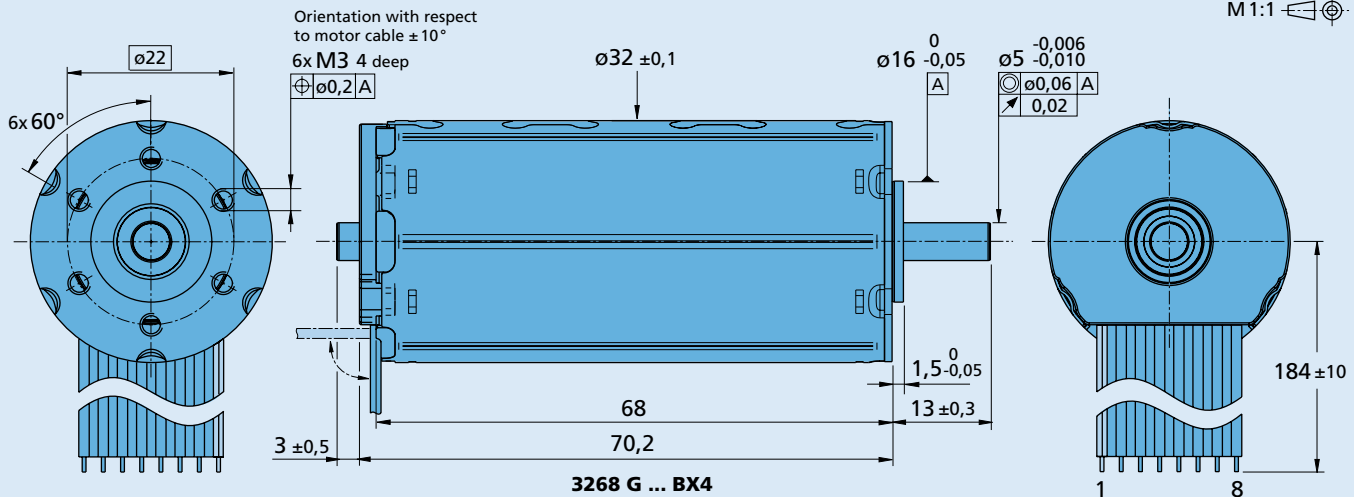

### Options

- Connector variant (Option no. 3830)

**Motor:**  
 AWG 24 / PVC ribbon cable  
 with connector Micro-Fit

- Analog Hall sensors (Option no. 3692)



### Full product description

- Examples:  
**3268G024BX4**

### Cable and connection information

