

# DC-Micromotors

## Graphite Commutation

# 131 mNm

For combination with

Gearheads:

38/1, 38/1 S, 38/2, 38/2 S, 38A, 44/1

Encoders:

HEDL 5540, HEDM 5500, HEDS 5500, HEDS 5540, IE3-1024, IE3-1024 L

## Series 3863 ... CR

Values at 22°C and nominal voltage	3863 H	012 CR	018 CR	024 CR	036 CR	048 CR		
1 Nominal voltage	$U_N$		12	18	24	36	48	V
2 Terminal resistance	R		0,16	0,36	0,64	1,55	2,58	$\Omega$
3 Output power	$P_{2nom.}$		205	211	214	201	217	W
4 Efficiency, max.	$\eta_{max.}$		83	84	85	86	86	%
5 No-load speed	$n_0$		5 600	5 900	5 800	5 800	5 800	rpm
6 No-load current, typ. (with shaft $\varnothing$ 6 mm)	$I_0$		0,335	0,232	0,168	0,112	0,084	A
7 Stall torque	$M_H$		1 424	1 394	1 455	1 363	1 461	mNm
8 Friction torque	$M_R$		6,5	6,5	6,5	6,5	6,5	mNm
9 Speed constant	$k_n$		480	332	240	160	120	rpm/V
10 Back-EMF constant	$k_E$		2,08	3,01	4,17	6,25	8,33	mV/rpm
11 Torque constant	$k_M$		19,9	28,8	39,8	59,8	79,7	mNm/A
12 Current constant	$k_I$		0,05	0,035	0,025	0,017	0,013	A/mNm
13 Slope of n-M curve	$\Delta n/\Delta M$		3,9	4,1	3,9	4,1	3,9	rpm/mNm
14 Rotor inductance	L		45	90	180	400	700	$\mu$ H
15 Mechanical time constant	$\tau_m$		4,8	4,8	4,8	4,8	4,7	ms
16 Rotor inertia	J		120	110	120	110	115	gcm <sup>2</sup>
17 Angular acceleration	$\alpha_{max.}$		119	127	121	124	127	$\cdot 10^3$ rad/s <sup>2</sup>
18 Thermal resistance	$R_{th1} / R_{th2}$	2,5 / 6						K/W
19 Thermal time constant	$\tau_{w1} / \tau_{w2}$	50 / 900						s
20 Operating temperature range:								
– motor			-30 ... +125					°C
– winding, max. permissible			+155					°C
21 Shaft bearings			ball bearings, preloaded					
22 Shaft load max.:								
– with shaft diameter			6					mm
– radial at 3 000 rpm (3 mm from bearing)			60					N
– axial at 3 000 rpm			6					N
– axial at standstill			50					N
23 Shaft play								
– radial	$\leq$		0,015					mm
– axial	$=$		0					mm
24 Housing material			steel, black coated					
25 Mass			390					g
26 Direction of rotation			clockwise, viewed from the front face					
27 Speed up to	$n_{max.}$		7 000					rpm
28 Number of pole pairs			1					
29 Magnet material			NdFeB					
<b>Rated values for continuous operation</b>								
30 Rated torque	$M_N$		69	99	129	126	131	mNm
31 Rated current (thermal limit)	$I_N$		4	4	4	2,6	2	A
32 Rated speed	$n_N$		5 430	5 660	5 510	5 500	5 550	rpm

**Note:** Rated values are calculated with nominal voltage and at a 22°C ambient temperature. The  $R_{th2}$  value has been reduced by 25%.

### Note:

The diagram indicates the recommended speed in relation to the available torque at the output shaft for a given ambient temperature of 22°C.

The diagram shows the motor in a completely insulated as well as thermally coupled condition ( $R_{th2}$  50% reduced).

The nominal voltage ( $U_N$ ) curve shows the operating point at nominal voltage in the insulated and thermally coupled condition. Any points of operation above the curve at nominal voltage will require a higher operating voltage. Any points below the nominal voltage curve will require less voltage.

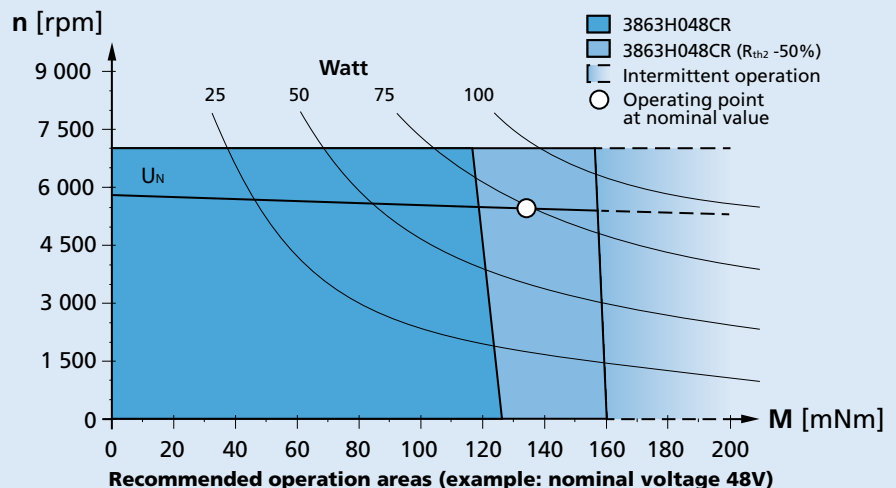

**Dimensional drawing**

Orientation with respect to motor terminals not defined

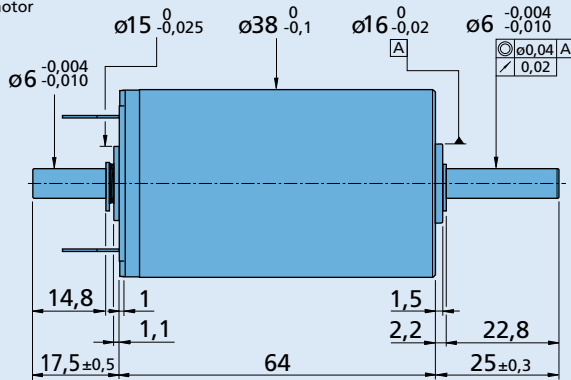
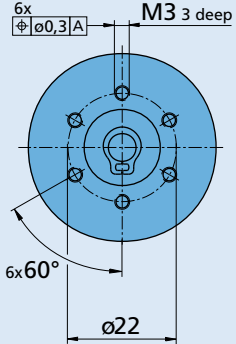

**3863 H ... CR**

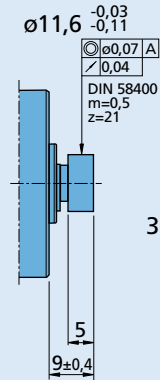

**3863 A ... CR**

Scale reduced  $\phi 25$  for screw M3 DIN 7500

