

Accessories

USB Programming Board

For combination with
Speed Controller:
SC 1801 S / F, SC 2804 S, SC 5008 S

Part No.: 6501.0009x

6501.00096 and 6501.00097			
Power supply for electronics	U_{elo}	5 ... 30	V
Power supply for motor	U_{mot}	0 ... 30	V
Current consumption of electronics	I_{el}	20	mA
Temperature range:			
– Operating temperature		0 ... + 65	°C
Dimensions and weight:			
– Dimensions (L x B x H)		55 x 48 x 18	mm
– Weight		35	g

General information

Standard programming board for configuration and changes of the operating modes for Speed Controller series SC 1801 S / F, SC 2804 S and SC 5008 S.

Automatic parameter download in connection with FAULHABER Motion Manager (from version 4.2) via USB interface.

Immediate test operation after successful data transfer within the customers application is feasible.

The programming board is to be operated via an USB interface. Therefore the installation of a special USB driver is required.

Driver installation

The driver is included in the setup package of FAULHABER Motion Manager (from version 4.2), which can be downloaded from the FAULHABER internet site www.faulhaber.com/MotionManager.

For detailed informations to install the driver please see instruction manual of SC programming board USB.

Connection diagram

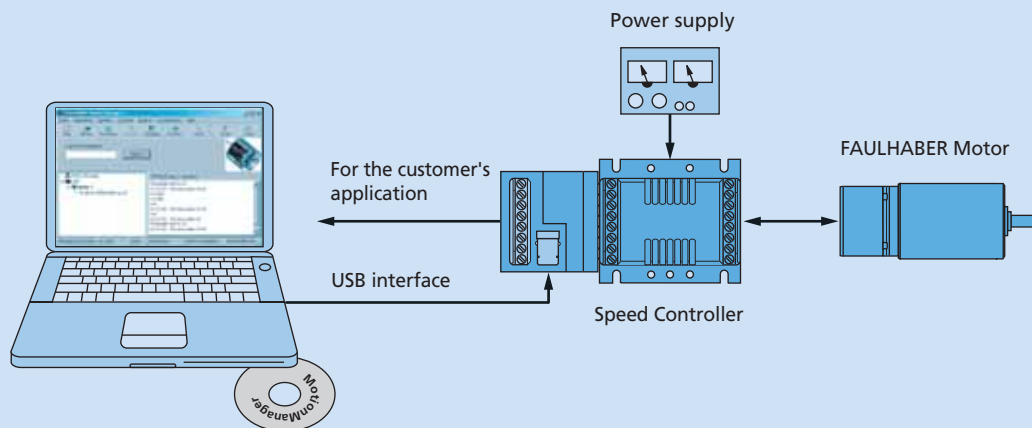

Dimensional drawing and connection information

