

# Encoders

## Optical Encoders with Line Driver

- Features:**  
 500 Lines per revolution  
 3 Channels + complementary outputs  
 Digital output  
 Line driver

### Series 5540

		HEDL 5540	
Lines per revolution	N	500	
Signal output, square wave		2+1 index and complementary outputs	
Supply voltage	V <sub>CC</sub>	4,5 ... 5,5	
Current consumption, typical (V <sub>CC</sub> = 5 V DC)	I <sub>CC</sub>	57	
Pulse width	P	180 ± 35	
Index pulse width	P <sub>O</sub>	90 ± 35	
Phase shift, channel A to B	Φ	90 ± 15	
Logic state width	S	90 ± 35	
Cycle	C	360 ± 5,5	
Signal rise/fall time, typical	tr/tf	0,25 / 0,25	
Frequency range <sup>1)</sup>	f	up to 100	
Inertia of code disc	J	0,6	
Operating temperature range		- 40 ... + 100	
<sup>1)</sup> Velocity (rpm) = f (Hz) x 60/N			

### Ordering information

Encoder type	number of channels	lines per revolution	For combination with:
HEDL 5540 A	2+1	500	DC-Micromotors 2230 ... S, 2233 ... S, 2342 ... CR 2642 ... CXR, 2657 ... CXR 3242 ... CR, 3257 ... CR, 3272 ... CR, 3557 ... CS, 3863 ... C, 3863 ... CR  brushless DC-Servomotors 2036 ... B, 2057 ... B, 2444 ... B, 3056 ... B, 3564 ... B

The housing dimensions of the HEDL encoder are the same as the HEDS/HEDM encoders, but there is a ribbon cable instead of plain connector pins.

Suggested Line Receivers: AM26LS32, SN75175, MC3486

### Features

These incremental shaft encoders in combination with the DC-Micromotors and Brushless DC-Servomotors are designed for the indication and control of both shaft velocity and direction of rotation as well as for positioning.

A LED source and lens system transmits collimated light through a low inertia metal disc to give two channels with 90° phase shift.

The index pulse is synchronized with the channel  $\bar{B}$ . Each encoder channel provides complementary output signals.

The single 5 volt supply and the digital output signals are interfaced with a connector.

The line driver offers enhanced performance when the encoder is used in noisy environments, or when it is required to drive long distances.

Motor with ball bearings are recommended for continuous operation at low and high speeds and for elevated radial shaft load.

Details for the motors and suitable reduction gearheads are on separate catalogue pages.

### Output signals / Circuit diagram / Connector information

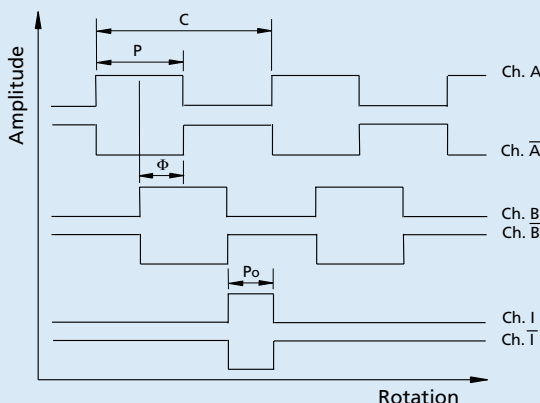

**Output signals HEDL 5540**  
with clockwise rotation as seen from the shaft end

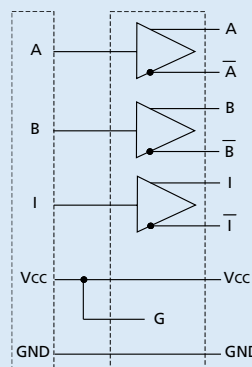

**Connection diagram**

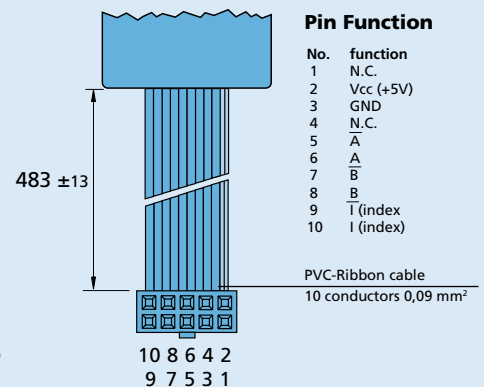

**Connector**  
DIN-41651  
grid 2,54 mm

### Pin Function

No.	function
1	N.C.
2	V <sub>CC</sub> (+5V)
3	GND
4	N.C.
5	A
6	A
7	B
8	B
9	I (index)
10	I (index)

scale reduced

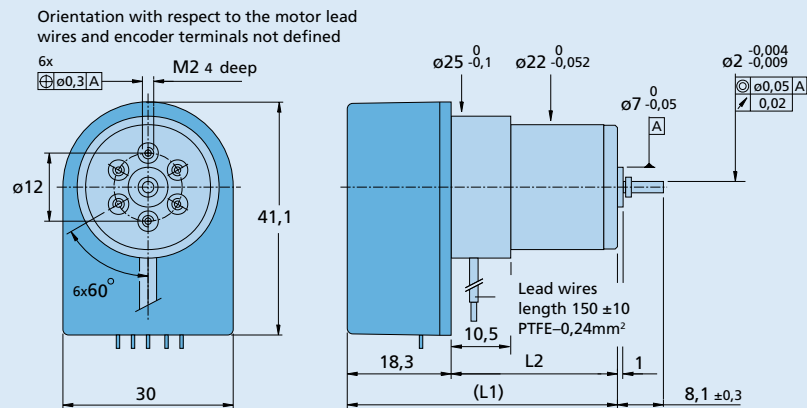

**Encoders HEDS 5500, 5540**  
with DC-Micromotors 2230, 2233

Motor type	L1	L2
2230	52,8	34,5
2233	55,6	37,3

scale reduced

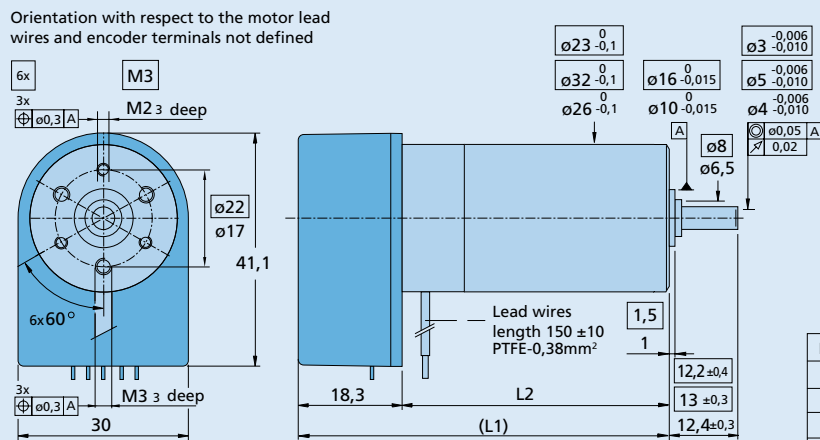

**Encoders HEDS 5500, 5540**  
with DC-Micromotors 2342, 2642, 2657, 3242, 3257

Motor type	L1	L2
2342	63,8	45,5
2642	64,8	46,5
2657	79,8	61,5
3242	65,3	47,0
3257	80,3	62,0

scale reduced

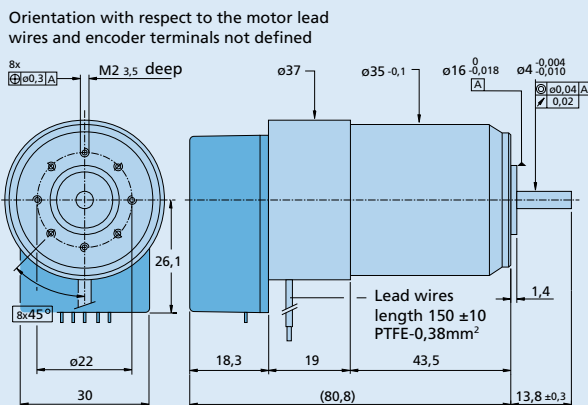

**Encoders HEDS 5500, 5540**  
with DC-Micromotor 3557

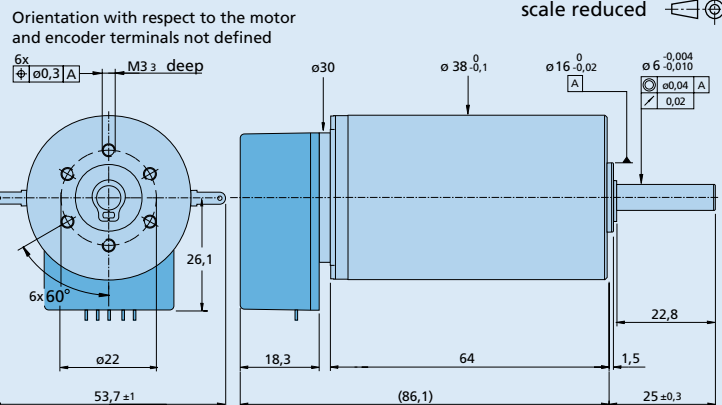

**Encoders HEDS 5500, 5540**  
with DC-Micromotor 3863

scale reduced

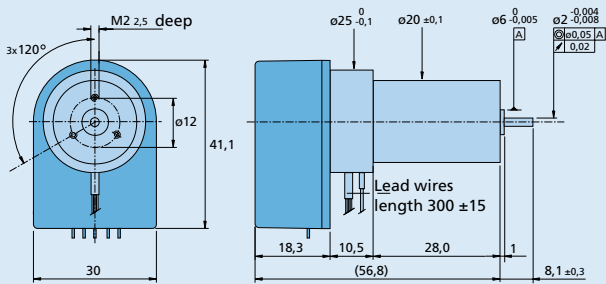

**Encoders HEDS 5500, 5540**  
with Brushless DC-Servomotor 2036 U ... B - K312

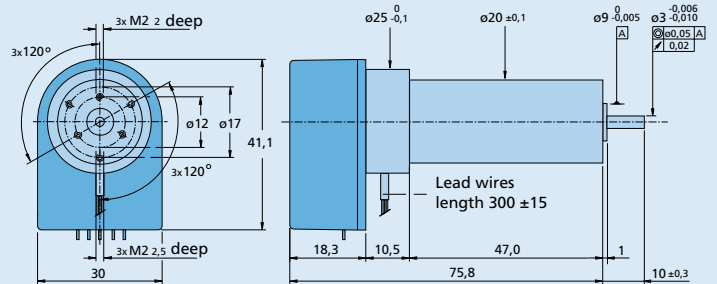

**Encoders HEDS 5500, 5540**  
with Brushless DC-Servomotor 2057 S ... B - K312

scale reduced

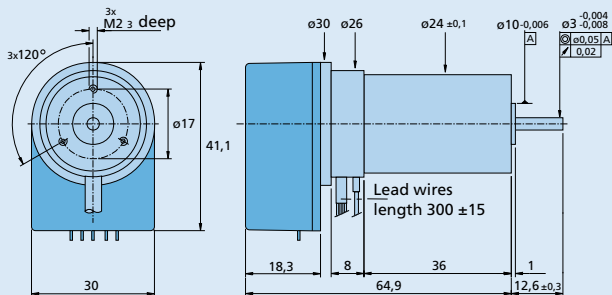

**Encoders HEDS 5500, 5540**  
with Brushless DC-Servomotor 2444 S ... B - K312

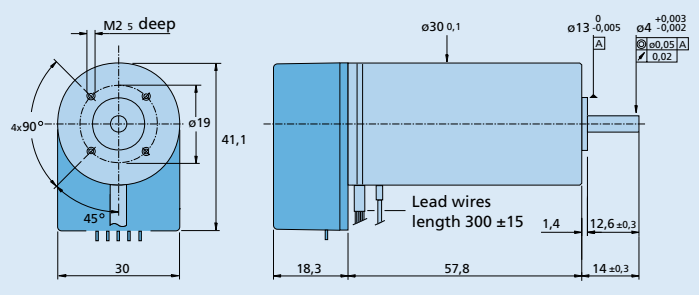

**Encoders HEDS 5500, 5540**  
with Brushless DC-Servomotor 3056 K ... B - K312

scale reduced

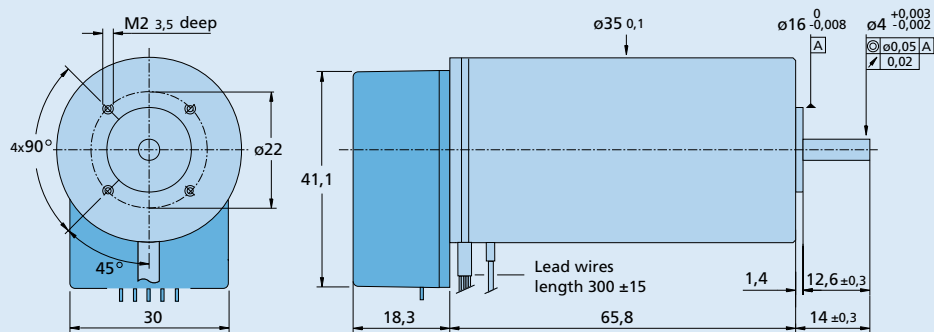

**Encoders HEDS 5500, 5540**  
with Brushless DC-Servomotor 3564 K ... B - K312