

Encoders

Magnetic Encoders

Features:
 64 to 1 024 Lines per revolution
 2 Channels
 Digital output

Series IE2 – 1 024

		IE2 – 64	IE2 – 128	IE2 – 256	IE2 – 512	IE2 – 1 024		
Lines per revolution	N	64	128	256	512	1 024		
Signal output, square wave		2					channels	
Supply voltage	V _{DD}	4,5 ... 5,5					V DC	
Current consumption, typical (V _{DD} = 5 V DC)	I _{DD}	typ. 6, max. 12					typ. 8,5	mA
Output current, max. ¹⁾	I _{OUT}	5						mA
Phase shift, channel A to B	Φ	90 ± 45						°e
Signal rise/fall time, max. (C _{LOAD} = 50 pF)	tr/tf	0,1 / 0,1						µs
Frequency range ²⁾ , up to	f	20	40	80	160	300		kHz
Inertia of code disc ³⁾	J	0,09						gcm ²
Operating temperature range		– 25 ... + 85						°C

¹⁾ V_{DD} = 5 V DC: Low logic level < 0,5 V, high logic level > 4,5 V: CMOS and TTL compatible

²⁾ Velocity (rpm) = f (Hz) x 60/N

³⁾ For the brushless DC-Servomotors the inertia of code disc is J = 0,14 gcm²

Ordering information

Encoder	number of channels	lines per revolution	in combination with:
IE2 – 64	2	64	DC-Micromotors 1336 ... CXR, 1516 ... SR, 1524 ... SR, 1717 ... SR, 1724 ... SR, 1727 ... C, 1741 ... CXR 2224 ... SR, 2232 ... SR, 2342 ... CR, 2642 ... CR, 2657 ... CR, 3242 ... CR, 3257 ... CR, 3272 ... CR 3863 ... C, 3863 ... CR Brushless DC-Servomotors 1628 ... B, 2036 ... B, 2057 ... B, 2444 ... B
IE2 – 128	2	128	
IE2 – 256	2	256	
IE2 – 512	2	512	
IE2 – 1 024	2	1024	

Features

These incremental shaft encoders in combination with the FAULHABER DC-Micromotors and Brushless DC-Servomotors are used for the indication and control of both shaft velocity and direction of rotation as well as for positioning.

The encoder is integrated in the DC-Micromotors SR-Series and extends the overall length by only 1,4 mm. Built-on option for DC-Micromotors and Brushless DC-Servomotors.

Hybrid circuits with sensors and a low inertia magnetic disc provide two channels with 90° phase shift.

The supply voltage for the encoder and the DC-Micromotor as well as the two channel output signals are interfaced through a ribbon cable with connector.

Details for the DC-Micromotors and suitable reduction gearheads are on separate catalogue pages.

Output signals / Circuit diagram / Connector information

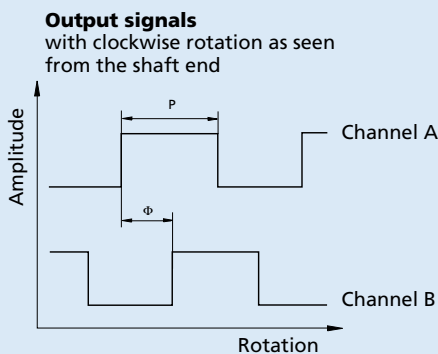

Admissible deviation of phase shift:

$$\Delta\Phi = \left| 90^\circ - \frac{\Phi}{P} * 180^\circ \right| \leq 45^\circ$$

Output circuit

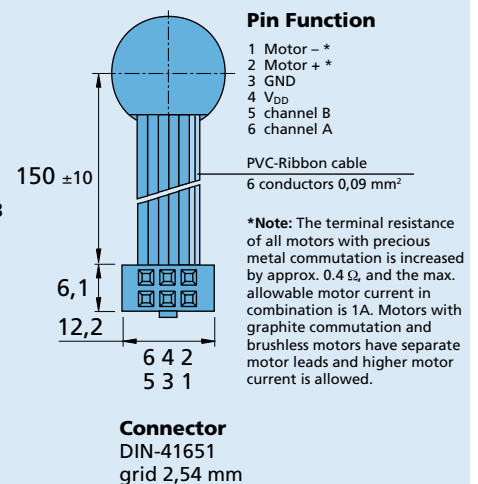
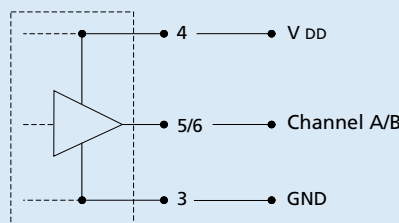

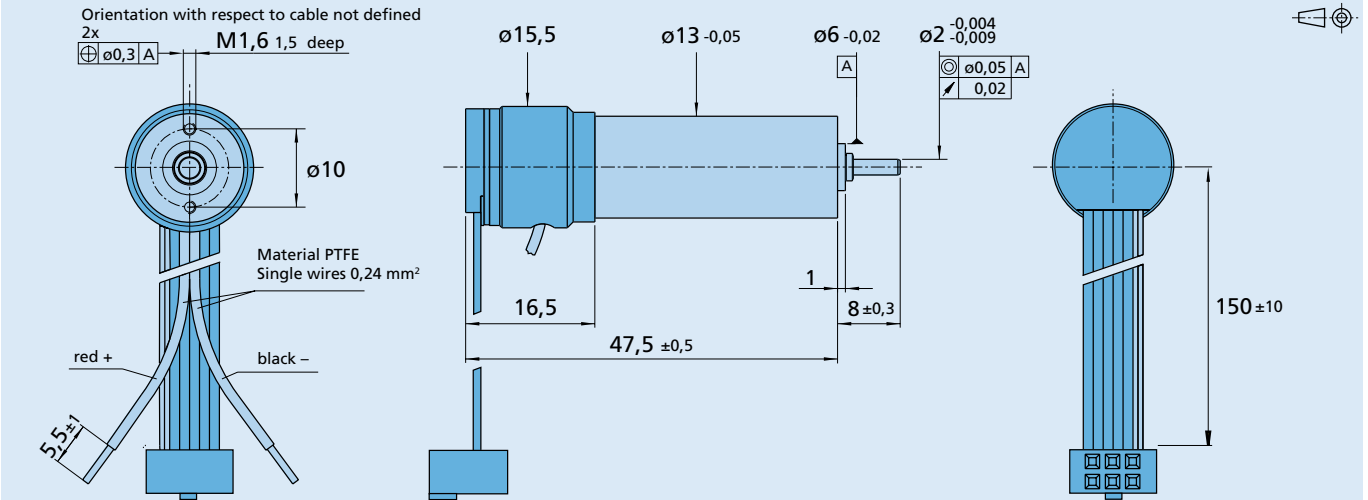
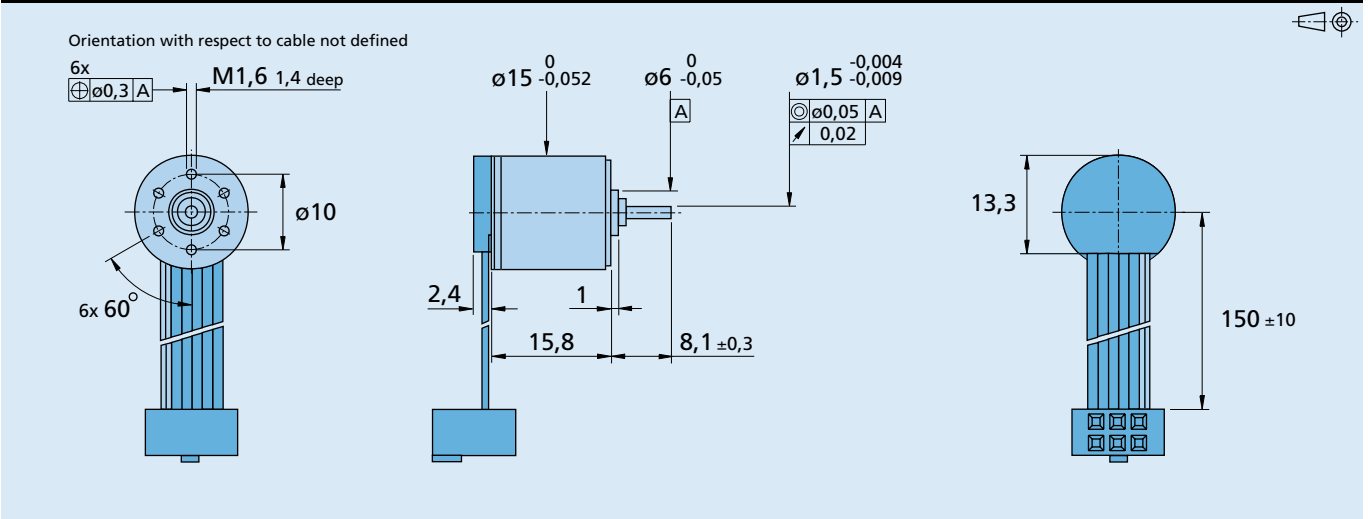
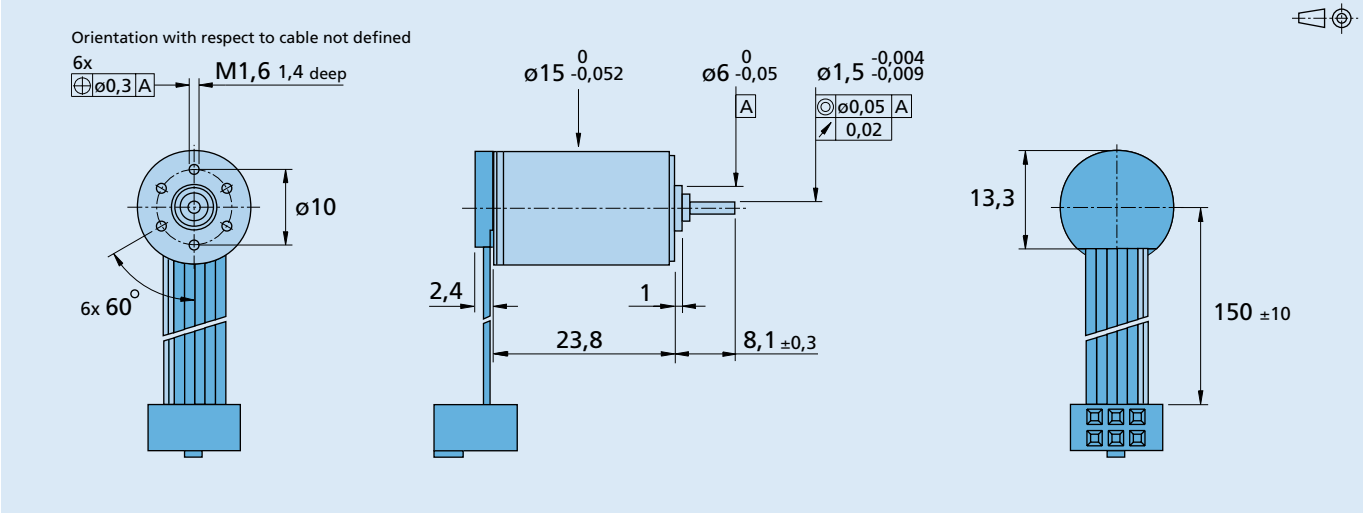
DC-Micromotor 1336 U ... CXR - 123 with Encoder IE2 - 16 ... 1 024

DC-Micromotor 1516 T ... SR with Encoder IE2 - 16 ... 1 024

DC-Micromotor 1524 T ... SR with Encoder IE2 - 16 ... 1 024

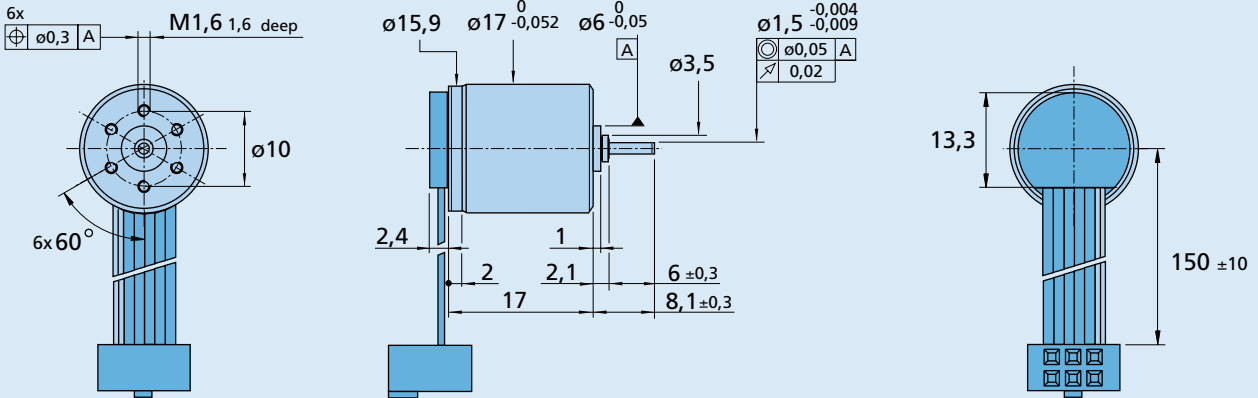
DC-Micromotor 1717 T ... SR with Encoder IE2 – 16 ... 1 024

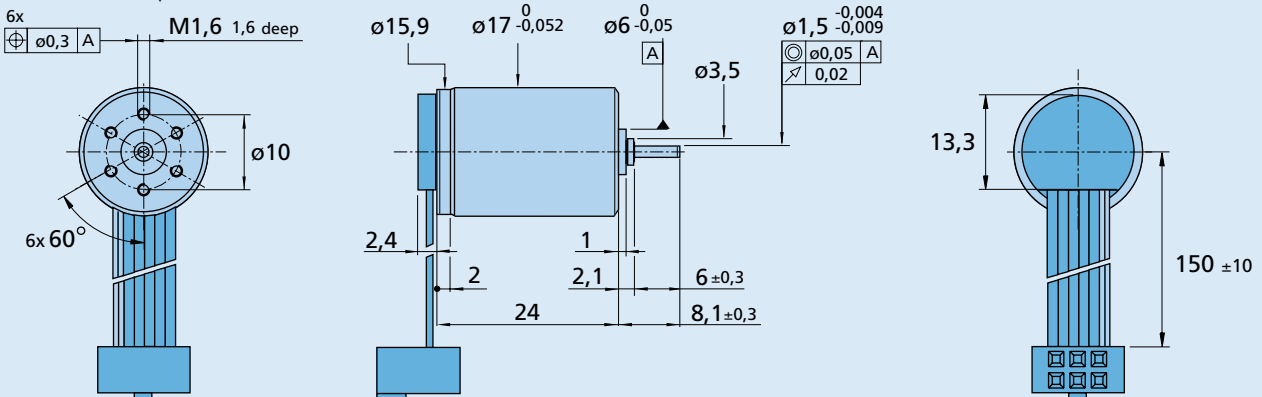

Orientation with respect to cable not defined



DC-Micromotor 1724 T ... SR with Encoder IE2 – 16 ... 1 024

Orientation with respect to cable not defined

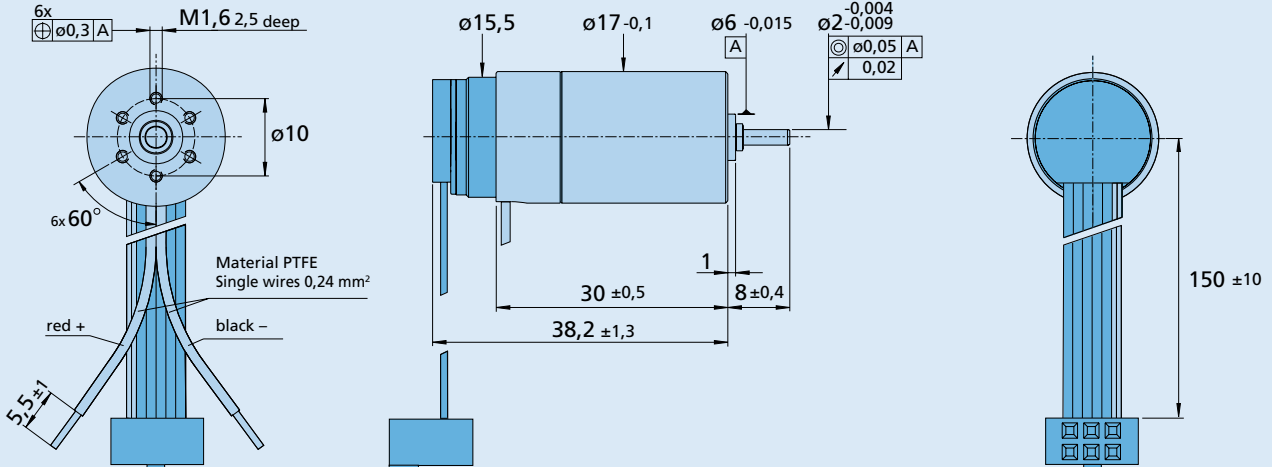

DC-Micromotor 1727 U ... C - 123 with Encoder IE2 – 16 ... 1 024

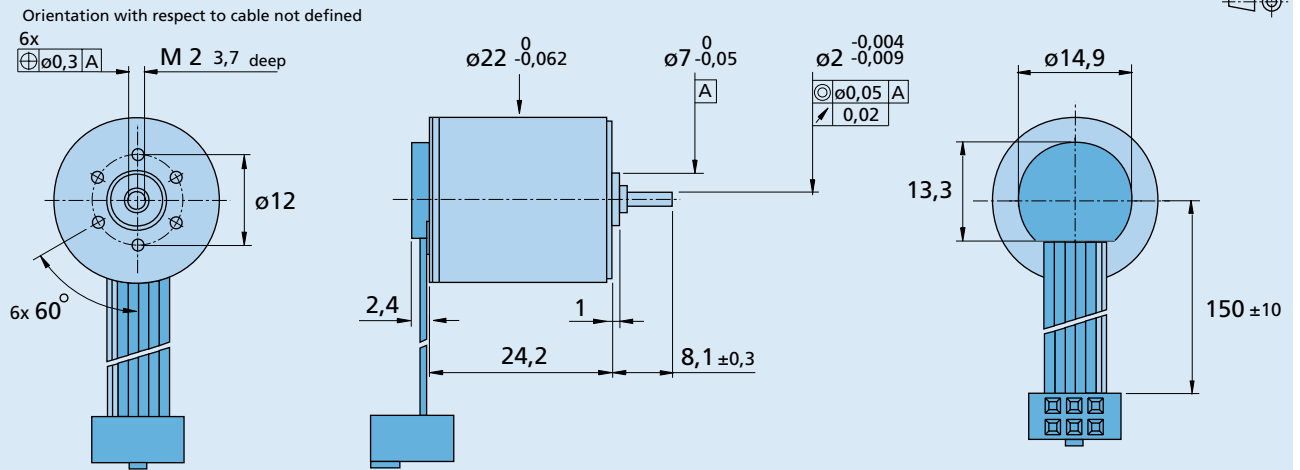
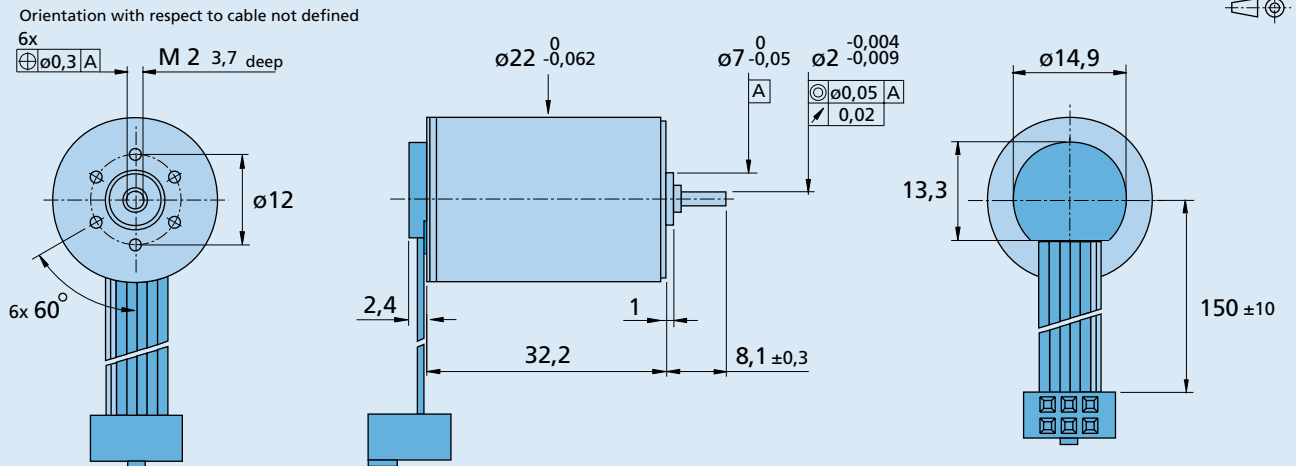
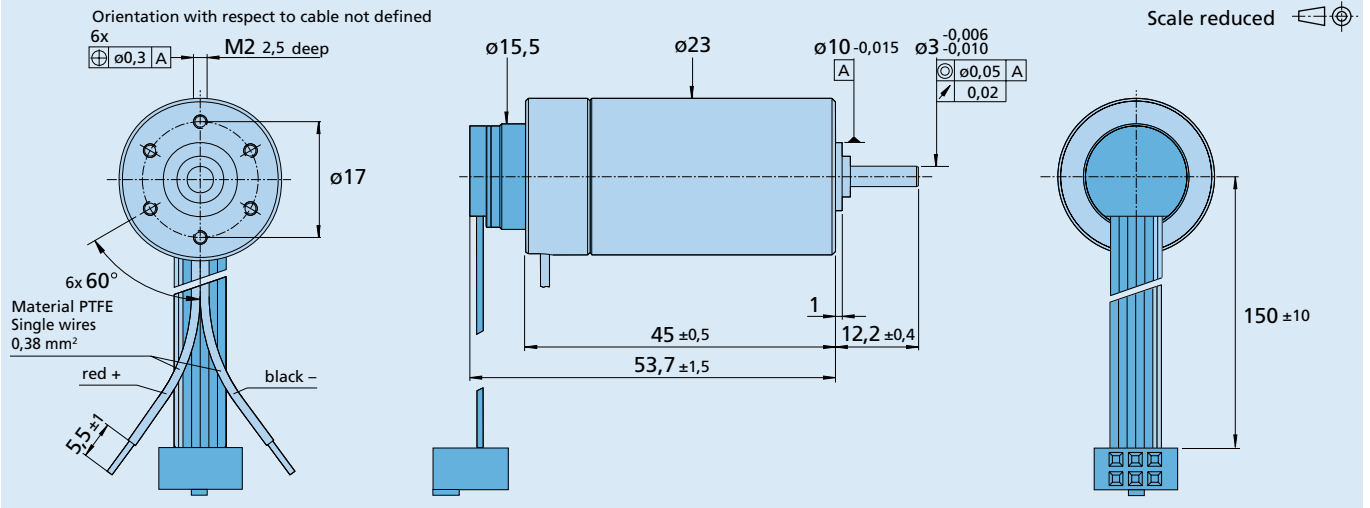
Orientation with respect to cable not defined

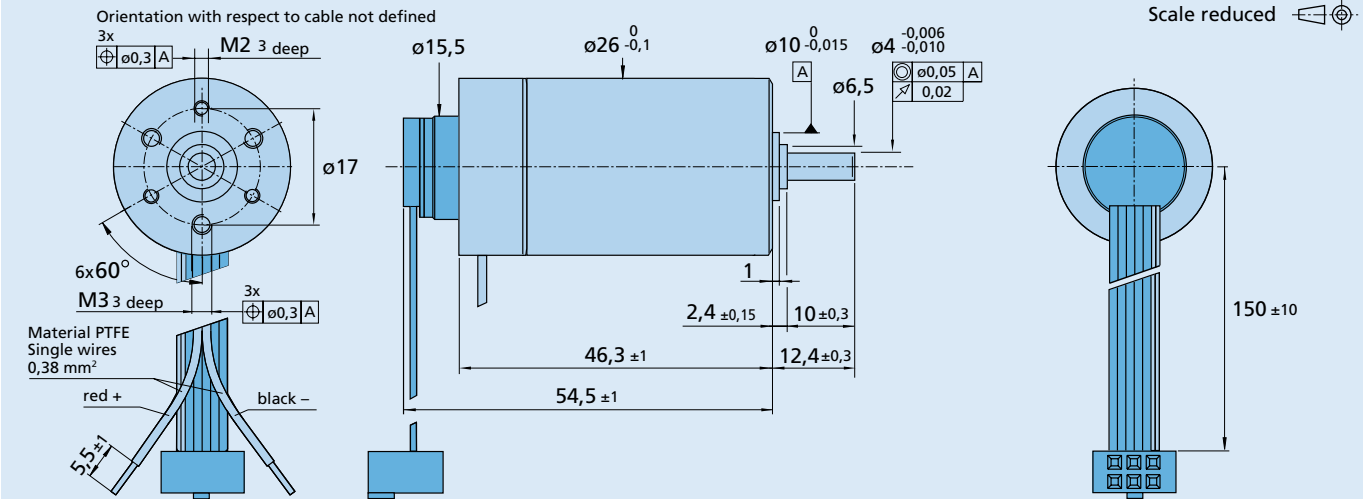

DC-Micromotor 2224 U ... SR with Encoder IE2 – 16 ... 1 024

DC-Micromotor 2232 U ... SR with Encoder IE2 – 16 ... 1 024

DC-Micromotor 2342 S ... CR with Encoder IE2 – 16 ... 1 024

DC-Micromotor 2642 W ... CR with Encoder IE2 16 – 1 024

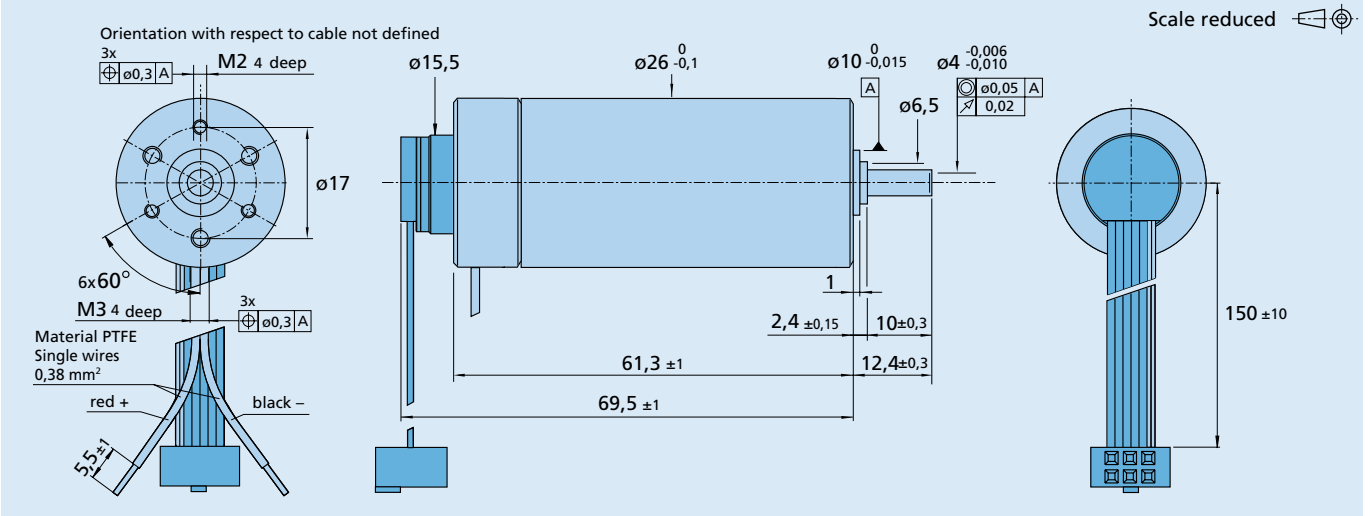

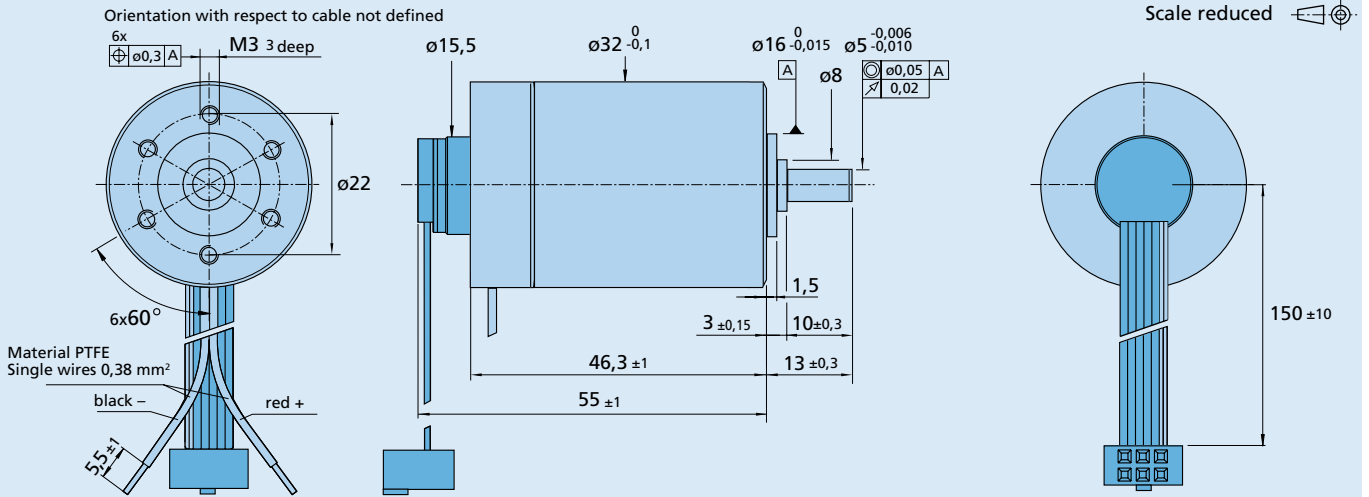
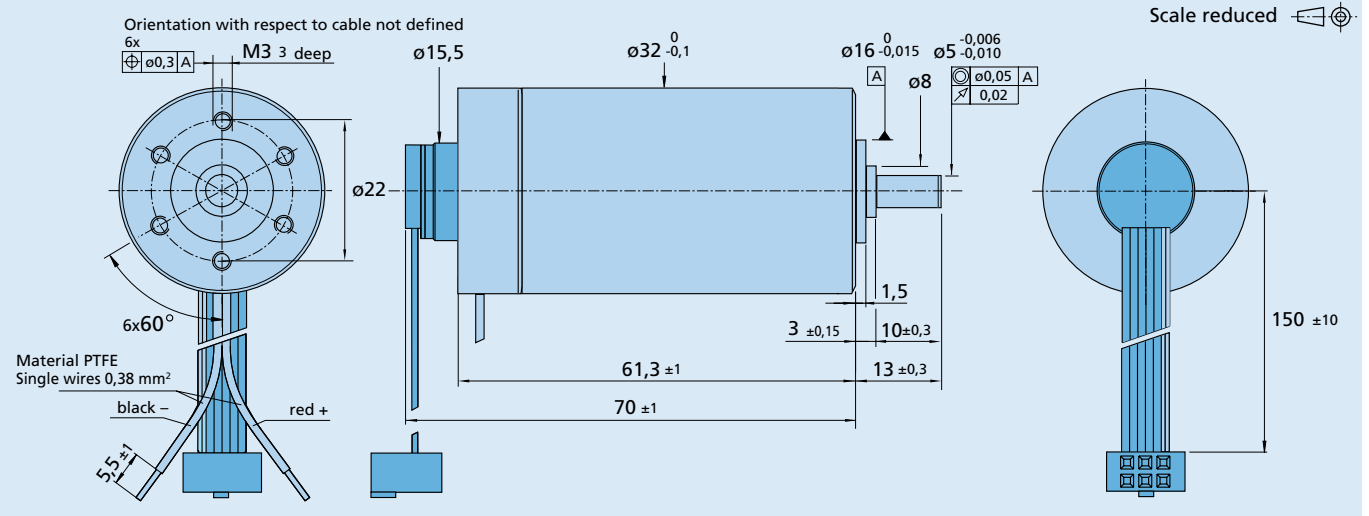
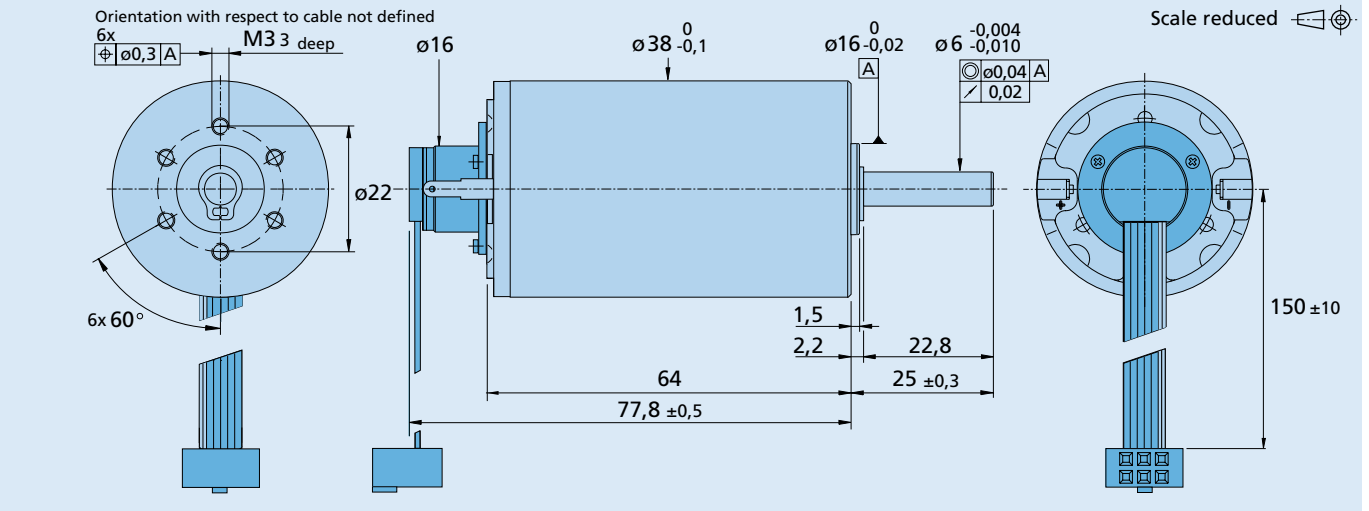
DC-Micromotor 2657 W ... CR with Encoder IE2 16 – 1 024



DC-Micromotor 3242 G ... CR with Encoder IE2 16 – 1 024

DC-Micromotor 3257 G ... CR with Encoder IE2 16 – 1 024

DC-Micromotor 3863 H ... C - 2016 with Encoder IE2 16 – 1 024

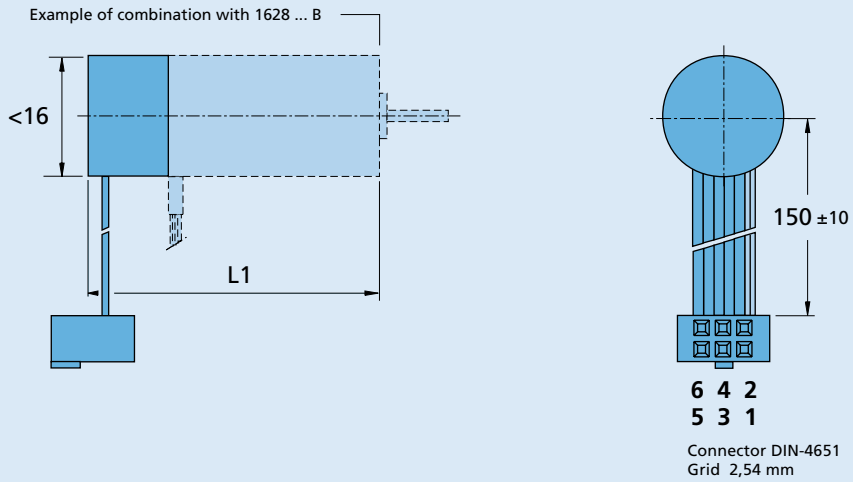
Brushless DC-Servomotors 1628... B - K313 , 2036 ... B - K313 , 2057 ... B - K313 and 2444 S ... B - K313 with Encoder IE2 – 64 ... 1 024

M 1:1 



Interface board for MCDC 3002 S



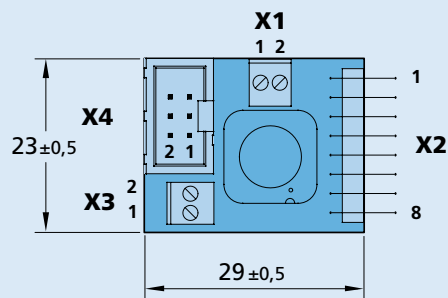

Interface board IE2
Part No.: 6501.00143