

Linear DC-Servomotors

3,6 N

for sin/cos control
QUICKSHAFT® Technology

Series LM 1247 ... 12

	LM 1247-	020-12	040-12	060-12	080-12	100-12	120-12	
1 Continuous force ¹⁾	F _{e max.}	3,6						N
2 Peak force ^{1) 2)}	F _{p max.}	10,7						N
3 Continuous current ¹⁾	I _{e max.}	0,55						A
4 Peak current ^{1) 2)}	I _{p max.}	1,66						A
5 Back-EMF constant	k _E	5,25						V/m/s
6 Force constant ³⁾	k _F	6,43						N/A
7 Terminal resistance, phase-phase	R	13,17						Ω
8 Terminal inductance, phase-phase	L	820						μH
9 Stroke length	s _{max.}	20	40	60	80	100	120	mm
10 Repeatability ⁴⁾		80	80	80	80	80	80	μm
11 Precision ⁴⁾		200	220	240	260	280	300	μm
12 Acceleration ⁵⁾	a _{e max.}	198,0	148,5	127,3	101,8	91,4	82,9	m/s ²
13 Speed ^{5) 6)}	v _{e max.}	2,0	2,4	2,8	2,9	3,0	3,2	m/s
14 Thermal resistance	R _{th 1} / R _{th 2}	3,2 / 20,0						K/W
15 Thermal time constant	τ _{w1} / τ _{w2}	11 / 624						s
16 Operating temperature range		- 20 ... +125						°C
17 Rod weight ⁷⁾	m _m	18	24	28	35	39	43	g
18 Total weight ⁷⁾	m _t	57	63	67	74	78	82	g
19 Magnetic pitch	τ _m	18						mm
20 Rod bearings		polymer sleeves						
21 Housing material		metal, non-magnetic						
22 Direction of movement		electronically reversible						

¹⁾ thermal resistance R_{th 2} by 55% reduced

²⁾ for max. 1 second with a duty cycle of 10%

³⁾ with sine wave commutation

⁴⁾ typical values with integrated linear Hall sensors (sin/cos) and Motion Controller Elmo "Whistle" SOL-WHI2.5/60I01.

The values depend on conditions of use

⁵⁾ theoretical value, referring only to the motor

⁶⁾ with a triangular speed profile and the max. stroke

⁷⁾ rounded value, for reference only

Notes: These motors are for operation with DC-voltage < 75 V DC.

The given values are for free standing motors.

The mounting with magnetic conductive metal can influence the characteristics of the motor.

For more information about drive electronics, please contact your local sales representative.

Caution: Presence of strong magnetic fields. Static sensitive device.

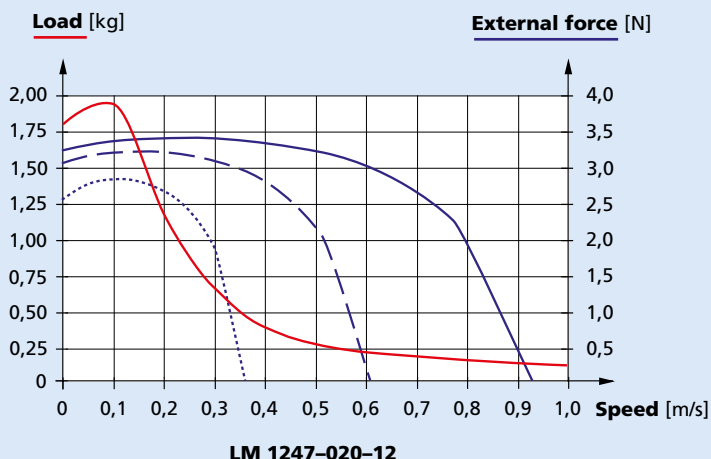

Trapezoidal motion profile (t₁ = t₂ = t₃)

Displacement distance:	20 mm
Friction coefficient:	0,2
Slope angle:	0°
Rest time:	0,1 s

Load: The max. permissible load at a given speed with an external force of 0 N

External force: The max. permissible external force at a given speed with a load of:

- 0,1 Kg —————
- 0,2 Kg - - - - -
- 0,5 Kg ·········

Linear DC-Servomotor LM 1247 ... 12 with axial connection

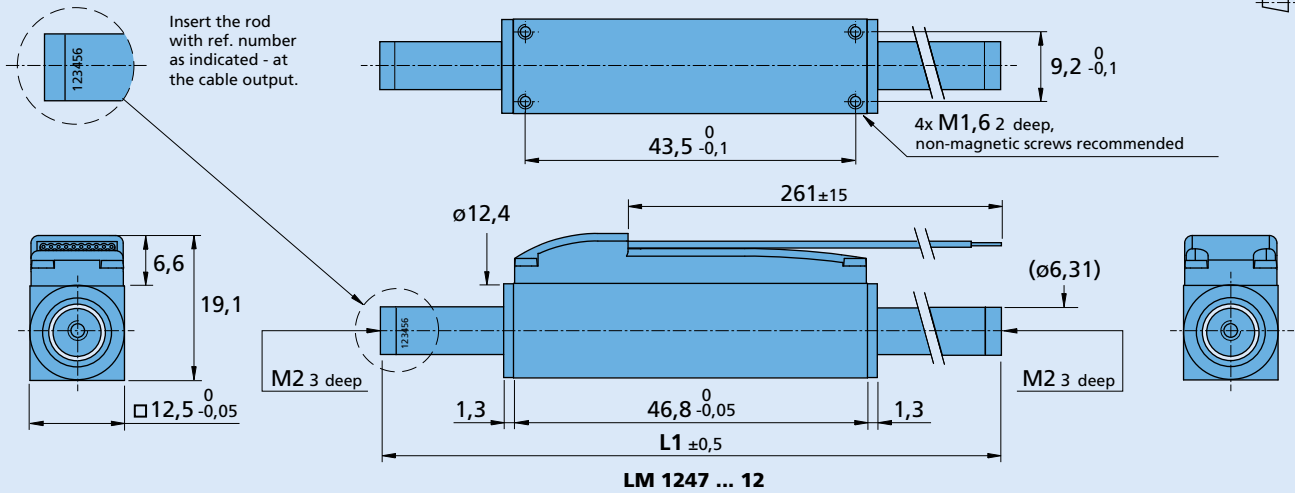

Ordering information

Linear DC-Servomotors Series

Stroke mm

Rod length L1 ±0,5 mm

Series	Stroke mm	Rod length L1 ±0,5 mm
LM 1247-020-12	-10 to +10	82
LM 1247-040-12	-20 to +20	109
LM 1247-060-12	-30 to +30	127
LM 1247-080-12	-40 to +40	154
LM 1247-100-12	-50 to +50	172
LM 1247-120-12	-60 to +60	190

Note: Single rod available on request.

Cable and connection information

Cable for LM 1247-...-12C

Material PVC, 10 conductors, AWG 28 with connector A05a - TCO, pitch 2 mm

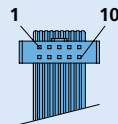
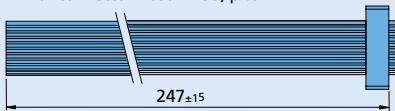

Cable for LM 1247-...-12

Material PVC, 10 conductors, AWG 28, grid 1mm, wires tinned

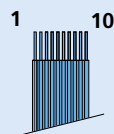
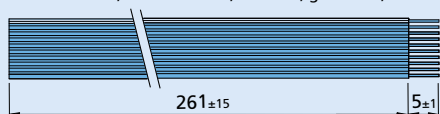

Cable for LM 1247-...-02

Single wires, material PVC, 10 conductors, AWG 28. Recommended connector: Molex - Nr. 51110-1060

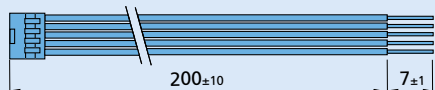

* The color reference refers only to the LM 1247-...-02 version.

Connection

LM 1247-...-02

PIN	Function	Color*
1	Phase C	yellow
7	Phase B	orange
8	Phase A	brown
4	GND	black
3	+5V	red
2	Sin +	green
5	Sin -	blue
6	Cos +	grey
9	Cos -	white
10	N.C.	purple

LM 1247-...-12 / 12C

PIN	Function
1	Phase C
2	Phase B
3	Phase A
4	GND
5	+5V
6	Sin +
7	Sin -
8	Cos +
9	Cos -
10	N.C.