

Linear DC-Servomotors

with Analog Hall Sensors
QUICKSHAFT® Technology

9,2 N

For combination with
Drive Electronics:
Motion Controller

Series LM 2070 ... 11

	LM 2070-	040-11	080-11	120-11	160-11	220-11	
1 Continuous force ¹⁾	F _{e max.}	9,2					N
2 Peak force ^{1) 2)}	F _{p max.}	27,6					N
3 Continuous current ¹⁾	I _{e max.}	0,79					A
4 Peak current ^{1) 2)}	I _{p max.}	2,37					A
5 Back-EMF constant	k _E	9,5					V/m/s
6 Force constant ³⁾	k _F	11,64					N/A
7 Terminal resistance, phase-phase	R	10,83					Ω
8 Terminal inductance, phase-phase	L	1 125					μH
9 Stroke length	s _{max.}	40	80	120	160	220	mm
10 Repeatability ⁴⁾		60	60	60	60	80	μm
11 Precision ⁴⁾		200	300	400	500	600	μm
12 Acceleration ⁵⁾	a _{e max.}	93,9	65,7	54,8	46,0	36,8	m/s ²
13 Speed ^{5) 6)}	v _{e max.}	1,9	2,3	2,6	2,7	2,8	m/s
14 Thermal resistance	R _{th 1} / R _{th 2}	3,1 / 9,3					K/W
15 Thermal time constant	τ _{w1} / τ _{w2}	30 / 1 200					s
16 Operating temperature range		- 20 ... +125					°C
17 Rod weight ⁷⁾	m _m	98	140	168	200	250	g
18 Total weight ⁷⁾	m _t	236	278	306	338	388	g
19 Magnetic pitch	τ _m	24					mm
20 Rod bearings		polymer sleeves					
21 Housing material		metal, non-magnetic					
22 Direction of movement		electronically reversible					

¹⁾ thermal resistance R_{th 2} by 55% reduced

²⁾ for max. 1 second with a duty cycle of 10%

³⁾ with sine wave commutation

⁴⁾ typical values with integrated linear Hall sensors and Motion Controller.

The values depend on conditions of use

⁵⁾ theoretical value, referring only to the motor

⁶⁾ with a triangular speed profile and the max. stroke

⁷⁾ rounded value, for reference only

Notes: These motors are for operation with DC-voltage < 75 V DC.

The given values are for free standing motors.

The mounting with magnetic conductive metal can influence the characteristics of the motor.

Caution: Presence of strong magnetic fields. Static sensitive device.

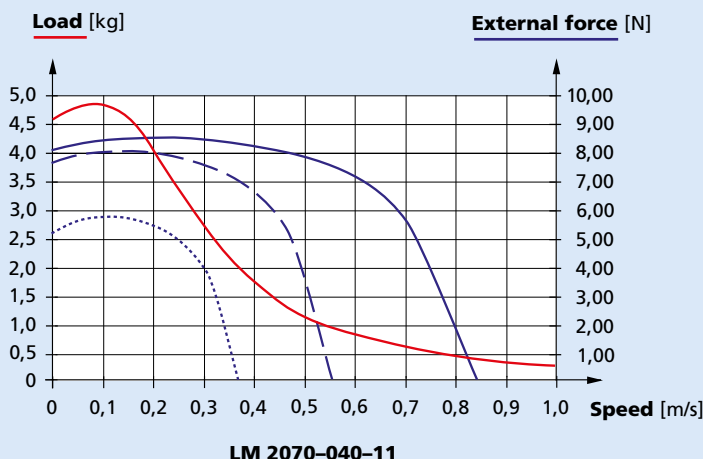

Trapezoidal motion profile (t₁ = t₂ = t₃)

Displacement distance:	40 mm
Friction coefficient:	0,2
Slope angle:	0°
Rest time:	0,1 s

Load: The max. permissible load at a given speed with an external force of 0 N

External force: The max. permissible external force at a given speed with a load of:

- 0,5 Kg —————
- 1,0 Kg - - - - -
- 2,0 Kg ·········

Linear DC-Servomotor LM 2070 ... 11 with axial connection

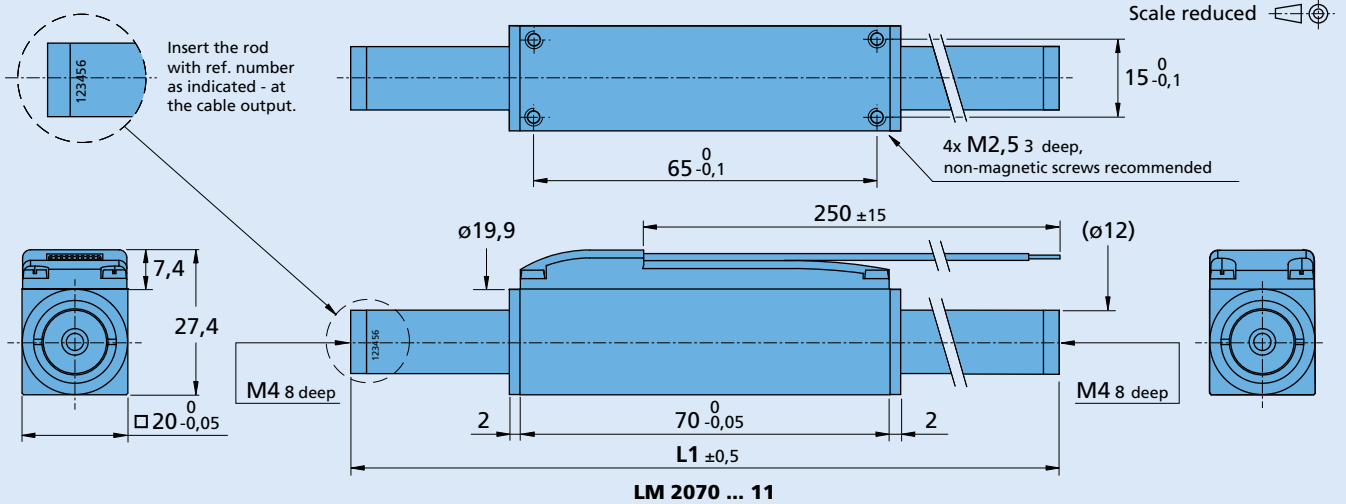

Ordering information

Linear DC-Servomotors Series

Series	Stroke mm	Rod length L1 ±0,5 mm
LM 2070-040-11	- 20 0 + 20	134
LM 2070-080-11	- 40 0 + 40	182
LM 2070-120-11	- 60 0 + 60	218
LM 2070-160-11	- 80 0 + 80	254
LM 2070-220-11	- 110 0 + 110	314

Note: Single rod available on request.

Cable and connection information

Cable for LM 2070-...-11C

Material PVC, 10 conductors, AWG 28 with connector A05a - TCO, pitch 2 mm

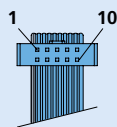
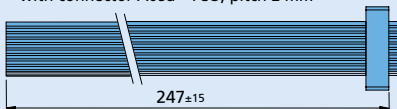

Cable for LM 2070-...-11

Material PVC, 10 conductors, AWG 28, grid 1mm, wires tinned

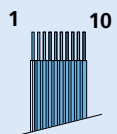
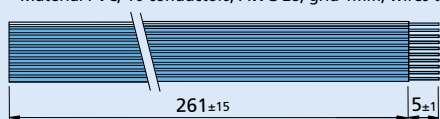

Cable for LM 2070-...-01

Single wires, material PVC, 10 conductors, AWG 28. Recommended connector: Molex - Nr. 51110-1060

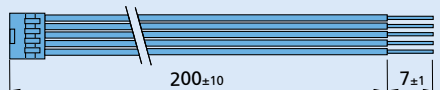

* The color reference refers only to the LM 2070-...-01 version.

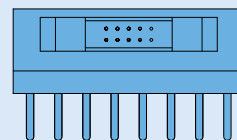

Adapter for LM 2070-...-11C
for connection with Motion Controllers MCLM 3006 S RS/CF (part no. L12.90.02).

Connection LM 2070-...-01

PIN	Function	Color*
1	Phase C	yellow
7	Phase B	orange
8	Phase A	brown
4	GND	black
3	+5V	red
6	Hall sensor C	grey
5	Hall sensor B	blue
2	Hall sensor A	green
9	N.C.	white
10	N.C.	purple

LM 2070-...-11 / 11C

PIN	Function
1	Phase C
2	Phase B
3	Phase A
4	GND
5	+5V
6	Hall sensor C
7	Hall sensor B
8	Hall sensor A
9	N.C.
10	N.C.