

NEW

Motion Controller

V2.5, 4-Quadrant PWM
with RS232 or CAN interface

For combination with:
DC-Micromotors

Series MCDC 3002

		MCDC 3002 P	MCDC 3002 F	MCDC 3002 S	
Power supply	U_B	5 ... 30	5 ... 30	5 ... 30	V DC
PWM switching frequency	f_{PWM}	78,12	78,12	78,12	kHz
Efficiency	η	95	95	95	%
Max. continuous output current ¹⁾	I_{dauer}	2	2	2	A
Max. peak output current	I_{max}	3	3	3	A
Total standby current	I_{el}	0,04	0,04	0,04	A
Speed range		5 ... 30 000	5 ... 30 000	5 ... 30 000	rpm
Scanning rate	N	100	100	100	μ s
External encoder resolution		$\leq 65\,535$	$\leq 65\,535$	$\leq 65\,535$	inc./rev.
Input/output (partially free configurable)		5	5	5	
Program memory: ²⁾					
– memory size		3,3	3,3	3,3	kWord
– Number of instructions		ca. 1 000	ca. 1 000	ca. 1 000	instructions
Operating temperature range		-25 ... +85	-25 ... +85	-25 ... +85	°C
Weight		7	13	16	g

¹⁾ at 22°C ambient temperature

²⁾ Only for version with serial interface

Connection information

Connection communication:					
Interface		RS232	CAN		
Communication profile		Faulhaber - ASCII	CANopen		
Max. transfer speed rate RS232		115 200			baud
Max. transfer speed rate CAN			1		Mbit/s
Connection 3 "AGND":					
– analog ground		analog GND			
– digital input		channel B			
external encoder	R_{in}	10			k Ω
	f	≤ 400			kHz
Connection 4 "Fault":					
– digital input	R_{in}	100			k Ω
– digital output (open collector)	U	$\leq U_B$			V
	I	≤ 30			mA
	clear	switched to GND			
	set	high-impedance			
fault output	no error	switched to GND			
	error	high-impedance			
Connection 5 "AnIn":					
– analog input	set speed value	U_{in}	"AGND" as GND		
– digital input	PWM set speed value	f	± 10		V
		T	100 ... 2 000		Hz
	external encoder		50% ± 0 rpm		
		f	channel A		
	step frequency input	f	≤ 400		kHz
		f	≤ 400		kHz
		R_{in}	5		k Ω
Connection 6 "UB":					
	U_B		5 ... 30		V DC
Connection 7 "GND":					
			ground		
Connection 8 "3. In":					
– digital input	R_{in}		22		k Ω
– electronic supply voltage	U_{EL}		5 ... 30		V DC
Connection 9 "5. In":					
– digital input	R_{in}		22		k Ω
Connection 10 "4. In":					
– digital input	R_{in}		22		k Ω

Connection information

Connection 11-12 "Ch A", "Ch B":			
Encoder input	CH A CH B		encoder channel A encoder channel B
Integrated pullup resistance + 5V		R f	2,2 ≤ 400 kΩ kHz
Connection 13 "Ucc":			
Output voltage for external use ¹⁾		U _{out}	5 V
Load current		I _{out}	≤ 60 mA
Connection 14 "SGND":			
Signal GND			signal ground
Connection 15-16 "Mot +", "Mot -":			
Motor connection	Mot + Mot -		Motor + Motor -
PWM switching frequency		U _{out} f _{PWM}	0 ... U _B 78,12 V DC kHz

¹⁾ E.g. encoder

The signal level (PLC or TTL) of the digital inputs can be set over the interface (see operating instruction manual).
Standard (PLC): Low 0...4,5V / High 12,5V...U_B, TTL: Low 0...0,5V / High 2,5V...U_B

Options

- Separate power supply (Option no.: 3085)

Full product description

- Example:
MCDC 3002 S RS (RS232)
MCDC 3002 F CF (CANopen with Faulhaber CAN)
MCDC 3002 P RS (RS232)

Accessories

		Motor Type	Part No. for MCDC 3002 S
Encoder adapter	IE2	DC	6501.00143
	PA2-50 / PA2-100	DC	6501.00144
	HEM3-256 ¹⁾	DC	6501.00146
	HXM3-64	DC	6501.00145
Programming adapter	RS232/CAN	DC	for MCDC 3002 S, F 6501.00121

¹⁾ Only for U_{DD Enc} = 5V

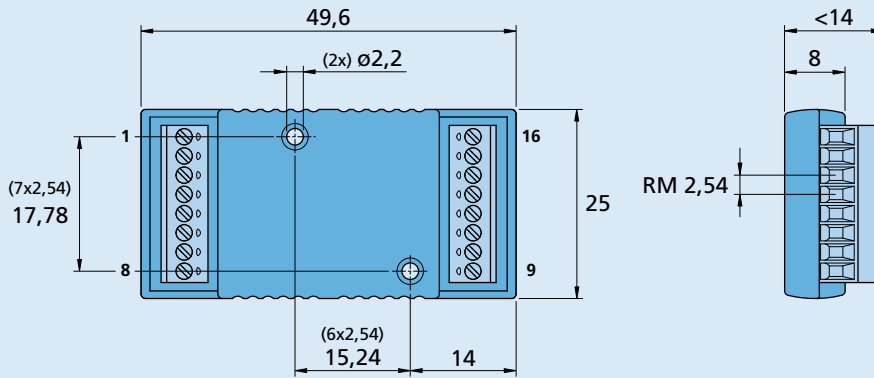
Dimensional drawing and connection information MCDC 3002 S

MCDC 3002 S
Supply connection

No.	Function
1	TxD / CAN_H
2	RxD / CAN_L
3	AGND
4	Fault
5	AnIn
6	U _B
7	GND
8	3. In

Motor connection

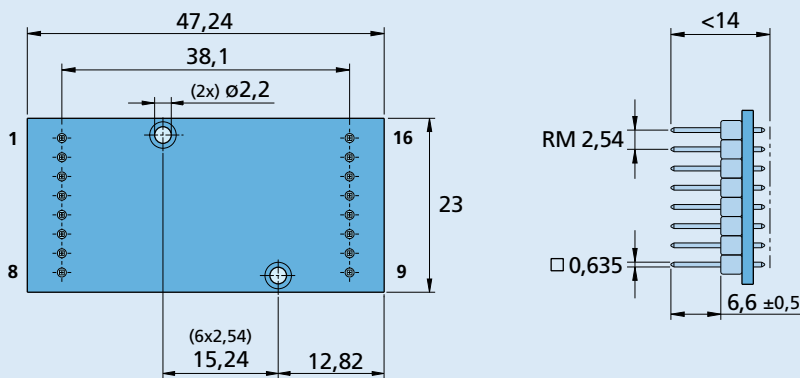
No.	Function
9	4. In
10	Ch A
11	Ch B
12	U _{CC}
13	SGND
14	Mot +
15	Mot -
16	5. In

Dimensional drawing and connection information MCDC 3002 P

MCDC 3002 P
Supply connection

No.	Function
1	TxD / CAN_H
2	RxD / CAN_L
3	AGND
4	Fault
5	AnIn
6	U _B
7	GND
8	3. In

Motor connection

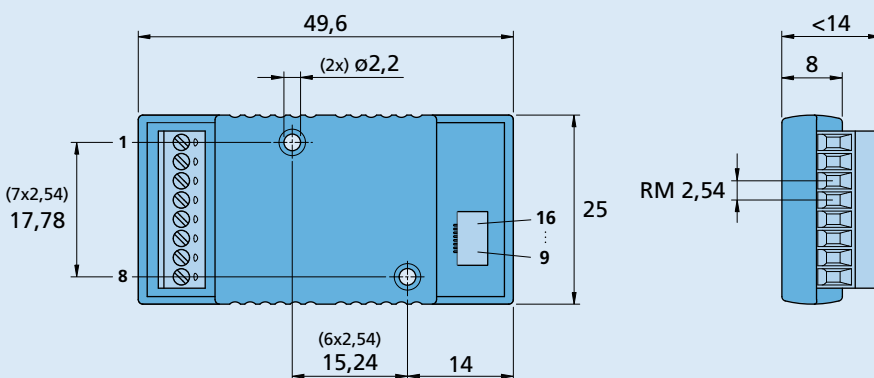
No.	Function
9	4. In
10	Ch A
11	Ch B
12	U _{CC}
13	SGND
14	Mot +
15	Mot -
16	5. In

Dimensional drawing and connection information MCDC 3002 F

MCDC 3002 F
Connector Information
 LIF-Connector 8-pole

Supply connection

No.	Function
1	TxD / CAN_H
2	RxD / CAN_L
3	AGND
4	Fault
5	AnIn
6	U _B
7	GND
8	3. In

Motor connection

No.	Function
9	4. In
10	Ch A
11	Ch B
12	U _{CC}
13	SGND
14	Mot +
15	Mot -
16	5. In

Connection information

Connection 11-12 "Ch A", "Ch B":			
Encoder input	CH A CH B		encoder channel A encoder channel B
Integrated pullup resistance + 5V		R f	2,2 ≤ 400 kΩ kHz
Connection 13 "Ucc":			
Output voltage for external use ¹⁾		U _{out}	5 V
Load current		I _{out}	≤ 60 mA
Connection 14 "SGND":			
Signal GND			signal ground
Connection 15-16 "Mot +", "Mot -":			
Motor connection	Mot + Mot -		Motor + Motor -
PWM switching frequency		U _{out} f _{PWM}	0 ... U _B 78,12 V DC kHz

¹⁾ E.g. encoder

The signal level (PLC or TTL) of the digital inputs can be set over the interface (see operating instruction manual).
Standard (PLC): Low 0...4,5V / High 12,5V...U_B, TTL: Low 0...0,5V / High 2,5V...U_B

Options

- Separate power supply (Option no.: 3085)

Full product description

- Example:
MCDC 3002 S RS (RS232)
MCDC 3002 F CF (CANopen with Faulhaber CAN)
MCDC 3002 P RS (RS232)

Accessories

		Motor Type	Part No. for MCDC 3002 S
Encoder adapter	IE2	DC	6501.00143
	PA2-50 / PA2-100	DC	6501.00144
	HEM3-256 ¹⁾	DC	6501.00146
	HXM3-64	DC	6501.00145
Programming adapter	RS232/CAN	DC	for MCDC 3002 S, F 6501.00121

¹⁾ Only for U_{DD Enc} = 5V

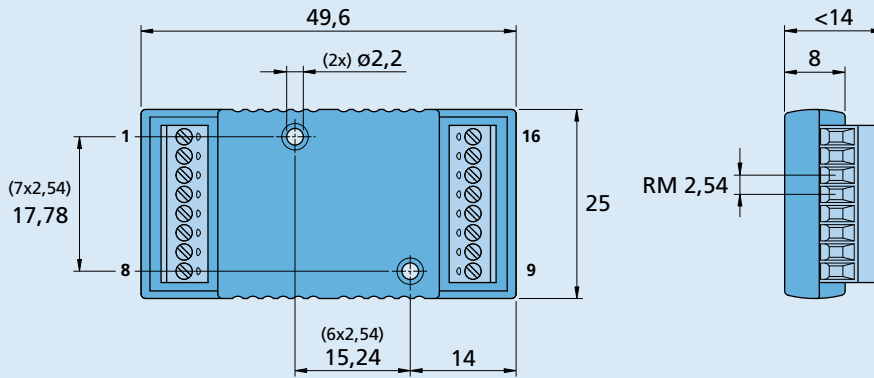
Dimensional drawing and connection information MCDC 3002 S

MCDC 3002 S
Supply connection

No.	Function
1	TxD / CAN_H
2	RxD / CAN_L
3	AGND
4	Fault
5	AnIn
6	U _B
7	GND
8	3. In

Motor connection

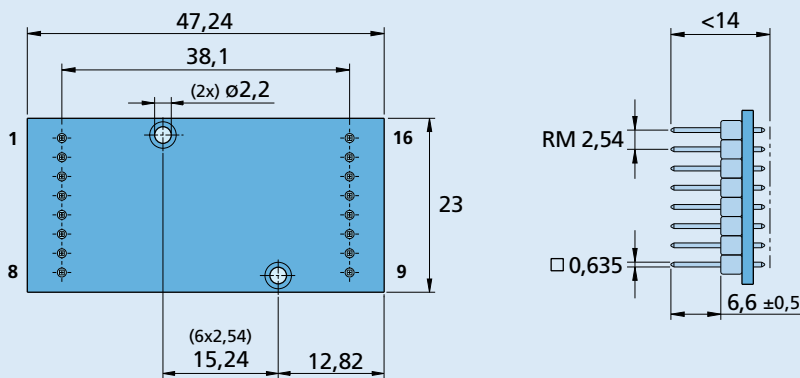
No.	Function
9	4. In
10	Ch A
11	Ch B
12	U _{CC}
13	SGND
14	Mot +
15	Mot -
16	5. In

Dimensional drawing and connection information MCDC 3002 P

MCDC 3002 P
Supply connection

No.	Function
1	TxD / CAN_H
2	RxD / CAN_L
3	AGND
4	Fault
5	AnIn
6	U _B
7	GND
8	3. In

Motor connection

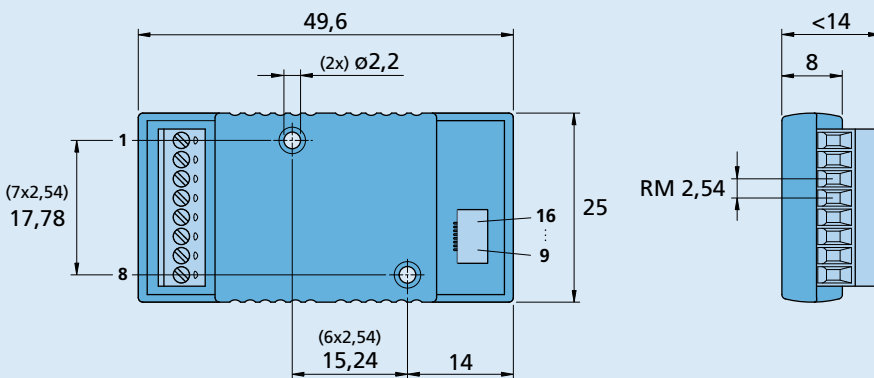
No.	Function
9	4. In
10	Ch A
11	Ch B
12	U _{CC}
13	SGND
14	Mot +
15	Mot -
16	5. In

Dimensional drawing and connection information MCDC 3002 F

MCDC 3002 F
Connector Information
 LIF-Connector 8-pole

Supply connection

No.	Function
1	TxD / CAN_H
2	RxD / CAN_L
3	AGND
4	Fault
5	AnIn
6	U _B
7	GND
8	3. In

Motor connection

No.	Function
9	4. In
10	Ch A
11	Ch B
12	U _{CC}
13	SGND
14	Mot +
15	Mot -
16	5. In