

# Speed Controller

4-Quadrant PWM  
configurable via PC

For combination with:  
DC-Micromotors and  
Brushless DC-Servomotors

## Series SC 5008

		SC 5008 S	
Power supply for electronic	U <sub>P</sub>	6 ... 50	V DC
Power supply for motor	U <sub>mot</sub>	0 ... 50	V DC
Max. continuous output current <sup>1)</sup>	I <sub>dauer</sub>	8	A
Max. peak output current	I <sub>max</sub>	16	A
Total standby current	I <sub>el max</sub>	100	mA
Input/output (partially free configurable)		5	
Tightening torque, terminal strip		0,5 ... 0,6	Nm
Weight		160	g
PWM switching frequency	f <sub>PWM</sub>	96 (24)	kHz
Efficiency	η	95	%
Speed range:			
– BL motors with Hall sensors (digital)		500 ... 100 000	rpm
– BL motors with Hall sensors (analog)		50 ... 60 000	rpm
– BL motors with absolute encoder		50 ... 60 000	rpm
– BL motors with digital Hall + encoder		50 ... 30 000	rpm
– DC motors with encoder		100 ... 30 000	rpm
Scanning rate		500 / 1 000	μs
Resolution of encoder with DC motors		≤ 65 535	inc./rev.
Operating temperature range		– 25 ... + 60	°C
Storage temperature		– 25 ... + 85	°C

<sup>1)</sup> at 22°C ambient temperature

### Versions

Speed Controller	Option	Version				Part No.
		Motor Type	Sensor Type	Set speed value specification <sup>1)</sup>	Speed at U <sub>nsoll</sub> = 10 V	
SC 5008 S	3530	BL	Hall sensors (digital) <sup>3)</sup>	0 ... 10 V	20 000 rpm	6500.01480
SC 5008 S	3531	DC	Incremental encoder <sup>2)</sup>	0 ... 10 V	10 000 rpm	6500.01482
SC 5008 S	4289	BL	Hall sensors (analog) <sup>3)</sup>	0 ... 10 V	20 000 rpm	6500.01484
SC 5008 S	3980	BL	Absolute encoder <sup>4)</sup>	0 ... 10 V	20 000 rpm	6500.01529
SC 5008 S	4475	BL	Digital Hall + encoder <sup>3)</sup>	0 ... 10 V	20 000 rpm	6500.01525
SC 5008 S	4476	BL	Digital Hall + brake/enable <sup>3)</sup>	0 ... 10 V	20 000 rpm	6500.01527

<sup>1)</sup> The velocity range can be configured by software. Versions with PWM and other configurations are available on request.

<sup>2)</sup> preset value is 512 lines

<sup>3)</sup> Factory pre-configured for 2 pole motors. For operation with 4 pole motors the speed controller must be reconfigured with the software "Faulhaber Motion Manager".

<sup>4)</sup> Factory pre-configured for 4 pole motors. For operation with 2 pole motors the speed controller must be reconfigured with the software "Faulhaber Motion Manager".

### Accessories

		Motor- typ	for SC 5008 S Part No.
Programming adapter	Starterkit		6501.00088
Programming adapter			6501.00096
Motor connector adapter	5 mm » 2,54 mm BX4	BL	6501.00087
Encoder adapter	IE2	DC	6501.00063
	HEDS	DC	6501.00001

**Dimensional drawing and connection information SC 5008 S**

 Scale reduced

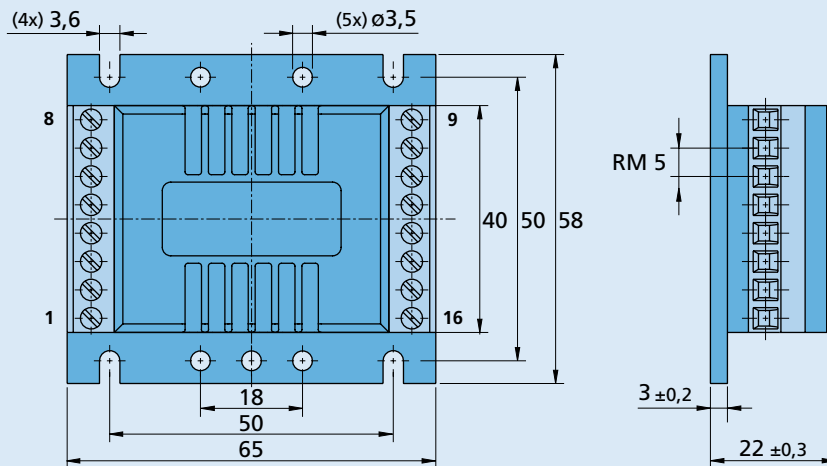

**Connection**

Pin	Function
1	U <sub>p</sub>
2	U <sub>mot</sub>
3	GND
4	U <sub>soill</sub>
5	DIR
6	FG
7	IO 2
8	IO 1
9	Mot C
10	Mot B
11	Mot A
12	SGND
13	V <sub>cc</sub>
14	Sens C
15	Sens B
16	Sens A

## SC Function

### Description of connections (Motor-dependent)

	DC-Motors with Encoder	BL-Motors with Hall sensors	BL-Motors with Absolute encoder	BL-Motors with digital Hall sensors + encoder	BL-Motors with digital Hall sensors + brake/enable
<b>Connection "Mot A", "Mot B", "Mot C":</b>					
- Motor connection	Mot A	Mot +	Phase A	Phase A	Phase A
	Mot B	Mot -	Phase B	Phase B	Phase B
	Mot C	reserved	Phase C	Phase C	Phase C
<b>Connection "Sens A", "Sens B", "Sens C":</b>					
- Sensor input	Sens A	reserved	Hall sensor A	Hall sensor A	Hall sensor A
	Sens B	encoder canal A	Hall sensor B	Hall sensor B	Hall sensor B
	Sens C	encoder canal B	Hall sensor C	Hall sensor C	Hall sensor C
	f	≤ 400 kHz			
<b>Connection „IO1“, „IO2“</b>					
- logic input	IO1	reserved	reserved	reserved	encoder B
	IO2	reserved	reserved	reserved	encoder A
					brake enable

### Connection information (general)

<b>Connection "Up":</b>	Up	power supply electronic
<b>Connection "U<sub>mot</sub>":</b>	U <sub>mot</sub>	power supply motor coil
<b>Connection "GND":</b>		ground
<b>Connection "U<sub>nsoll</sub>":</b>		(standard version)
- analog input	set speed value	motor stops
		motor starts
- digital input	PWM for set speed value	motor stopped
	duty cycle	half of maximum speed
		maximum speed
	input resistance	high
	signal level PLC	low
	signal level TTL <sup>3)</sup>	high
		low
<b>Connection "DIR":</b>		
- digital input	direction of rotation	counterclockwise
		clockwise
	input resistance	
<b>Connection "FG":</b>		
- fault output		open collector with pull-up resistor <sup>4)</sup>
- frequency output (BL motor only)		no error
		lines per revolution
<b>Connection "IO1", "IO2":</b>		
- digital input <sup>6)</sup>	n.c.	reserved
	signal level TTL	high
		low
	(IO2)	motor enabled
		motor disabled
	(IO1)	motor stopped
		motor run
<b>Connection "V<sub>cc</sub>":</b>		
output voltage	5 V DC	for external use
max. output current for	SC 1801 S, F, P	» I <sub>cc</sub> = 25 mA
	SC 2402 P	» I <sub>cc</sub> = 20 mA
	SC 2804 S	» I <sub>cc</sub> = 30 mA
	SC 5004 P	» I <sub>cc</sub> = 100 mA
	SC 5008 S	» I <sub>cc</sub> = 100 mA
<b>Connection "SGND":</b>		signal ground

<sup>1)</sup> > 10 V for set speed value not defined.

<sup>2)</sup> Data in parentheses apply to BL motors operating without sensors.

<sup>3)</sup> Not available for SC 5004 / SC 5008

<sup>4)</sup> 22 kΩ (SC 1801, SC 2402, SC 2804)

47 kΩ (SC 5004, SC 5008)

An additional external pull-up resistor can be added to improve the rise time.

Caution: I<sub>out</sub> max. 15 mA must not be exceeded.

<sup>5)</sup> Values apply to 2-pole motors. The given values double for 4-pole motors.

<sup>6)</sup> With appropriate hardware.

**Circuit diagram - brushless with Hall sensors (Option 3530)**

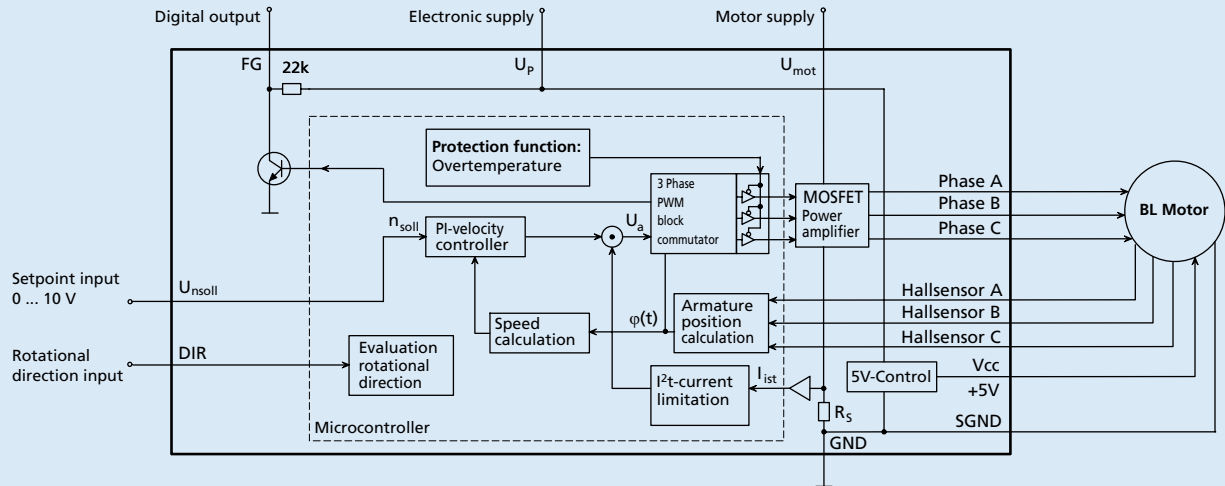

**Connection diagram supply unit**

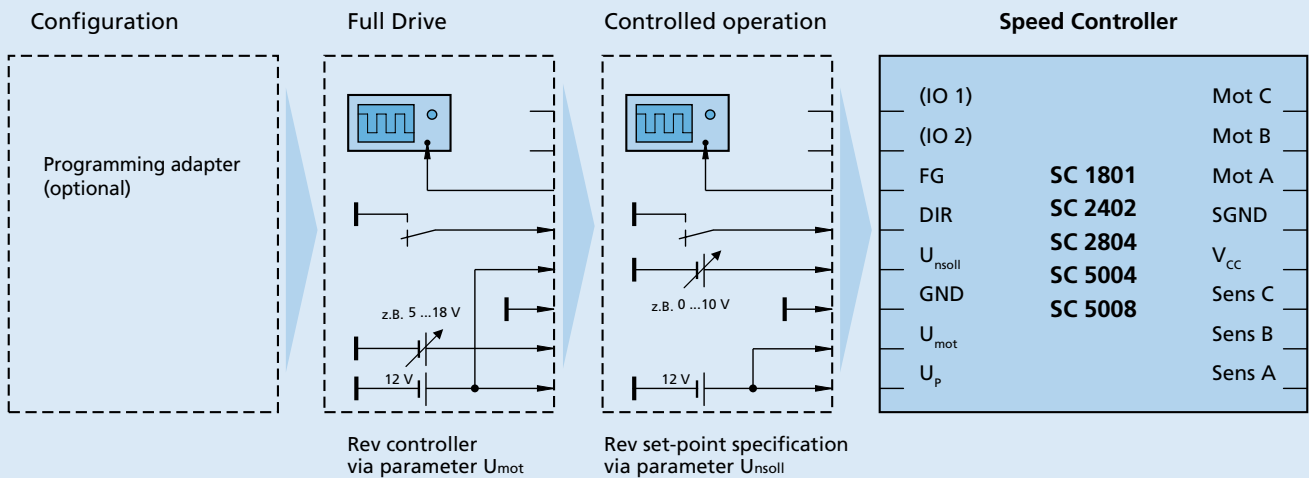

**Connection diagram operation mode DC-Micromotor with encoder**

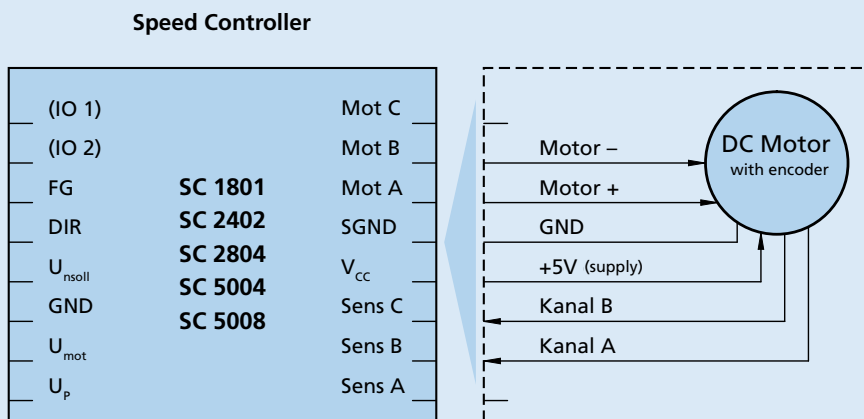

**Connection diagram operation mode BL motor with Hall Sensors**

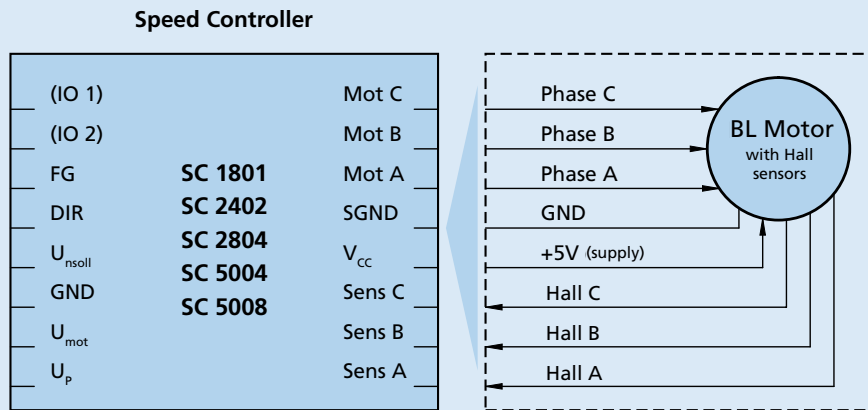

**Connection diagram operation mode BL motor with digital Hall Sensors and Encoder**

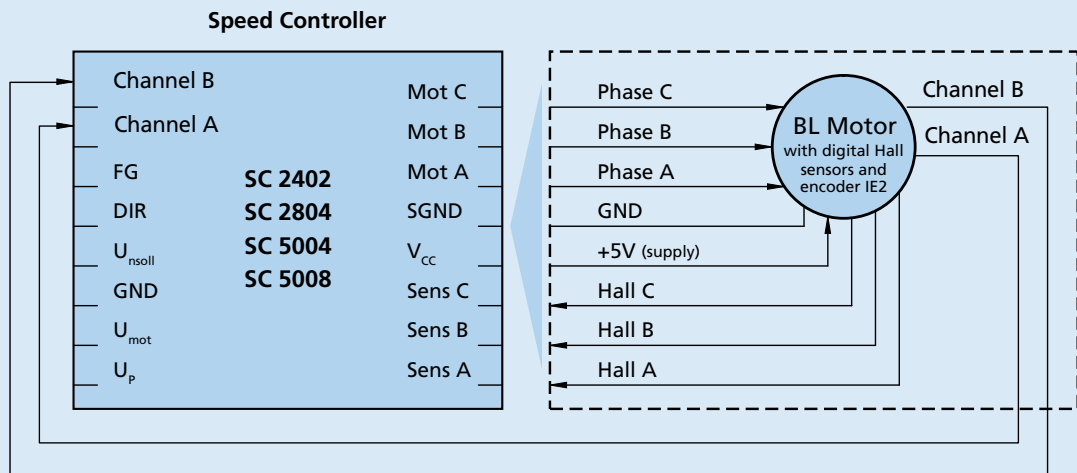

**Connection diagram operation mode BL motor with digital Hall Sensors and Brake / Enable**

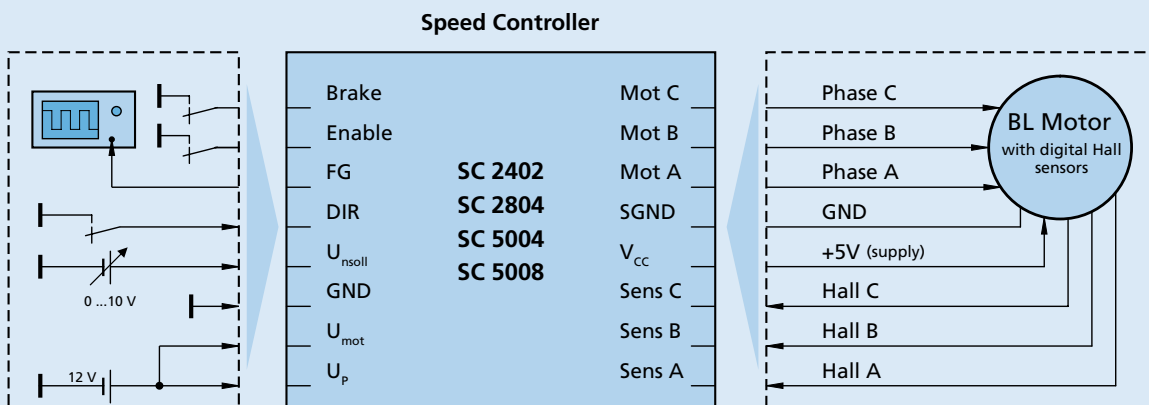

**Connection diagram operation mode BL motor with AES**

**Speed Controller**

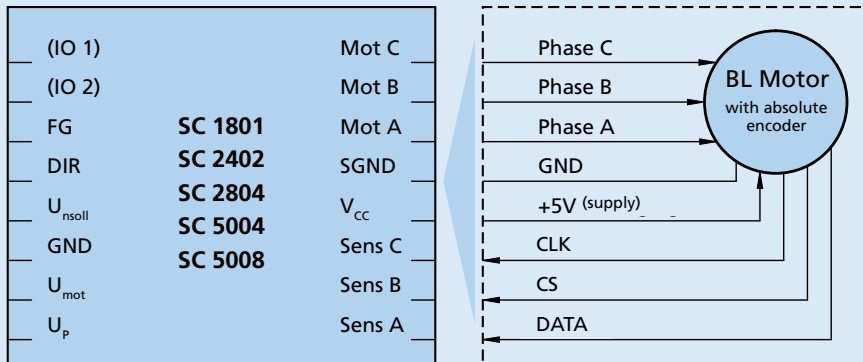

**Connection diagram operation mode DC and BL motor sensorless**

**Speed Controller**

