

- **Direct drive - backlash free**
- **Nanometer resolution**
- **Simple drive electronics**
- **No power draw in hold position**
- **Quick response and high speed**

The Piezo LEGS 20N linear motor is intended for a large range of OEM applications. Design focus has been for ease of integration. The very high speed dynamics and nanometer resolution makes it ideal for numerous applications.

The LEGS technology is characterized by its outstanding precision. Fast speed and quick response time, as well as long service life are other benefits. In combination with the nanometer resolution the technology is quite unique.

The motor is ideally suited for move and hold applications or for automatic adjustments. When the motor is in hold position it does not consume any power. The drive technology is direct, meaning no gears or lead screws are needed to create linear motion. This means the motor has no mechanical play or backlash. The Piezo LEGS 20N linear motor is available in a standard version and a vacuum version.

Mechanical and electrical connection

The motor is easily integrated in your application using the drive rod mechanical adapter. Drive rods are supplied in different lengths (30, 40, 50, 60, 70 and 101.8 mm).

The motor has two electrical connectors which are connected in parallel to the driver.

Operating modes

The motor can move in full steps (wfm-steps), or partial steps (microsteps) giving positioning resolution in the nanometer range. Speed is adjustable from single microsteps per second up to max specified.

Controlling the motor

PiezoMotor offers a range of drivers and controllers. The most basic one is a handheld push button driver. Another option is an analogue driver that regulates the motor speed by means of an ± 7 V analogue interface. One of the more advanced alternatives is the PMD101 Microstep Driver/Controller. This product enables the user to vary the waveform as well as speed. The PMD101 is equipped with encoder signal inputs for close loop control. The microstepping feature divides full step cycle into maximum 2048 increments which results in microsteps as small as two nanometers.



PMD101

Design your own driver

Some customers prefer to design their own driver for ease of integration or for even higher waveform resolution (sub-nanometer range). In this case PiezoMotor can provide information to assist in the design.

Ordering information

Motor

LT2010A-	Standard version, stainless steel
LT2010B-	Vacuum version, stainless steel

Drivers and Controllers

PMCM21-01	Handheld push button driver
PMCM31-01	Analogue driver
PMD101	Microstepping driver

Accessories

LEGS-LT CONNECT	Twin connect board
102431-05	Motor cable 0.5 m
102431-15	Motor cable 1.5 m

Operating Principle

The Piezo LEGS walking principle is of the non-resonant type, i.e. the position of the drive legs is known at any given moment. This assures very good control of the motion over the whole speed range.

The performance of a Piezo LEGS motor is different from that of a DC or stepper motor in several aspects. A Piezo LEGS motor is friction based, meaning the motion is transferred through contact friction between the drive leg and the drive rod. You cannot rely on each step being equal to the next. This is especially true if the motor is operated under varying loads, as shown in the diagram below. For each waveform cycle the Piezo LEGS motor will take one full step, referred to as one *wfm-step* (~5 μm at no load). In the schematic illustrations to the right, you can see one step being completed. The velocity of the drive rod is *wfm-step* length multiplied with waveform frequency (5 μm x 2 kHz = 10 mm/s).

Microstepping is achieved by dividing the *wfm-step* into discrete points. The resolution will be a combination of the the number of points in the waveform, and the load. Example: at 9 N load the typical *wfm-step* length is ~4 μm , and with 2048 discrete points in the waveform the microstep resolution will be ~2 nm. In analog bending mode or with higher resolution D/A converter it is possible to position in the sub nanometer region.

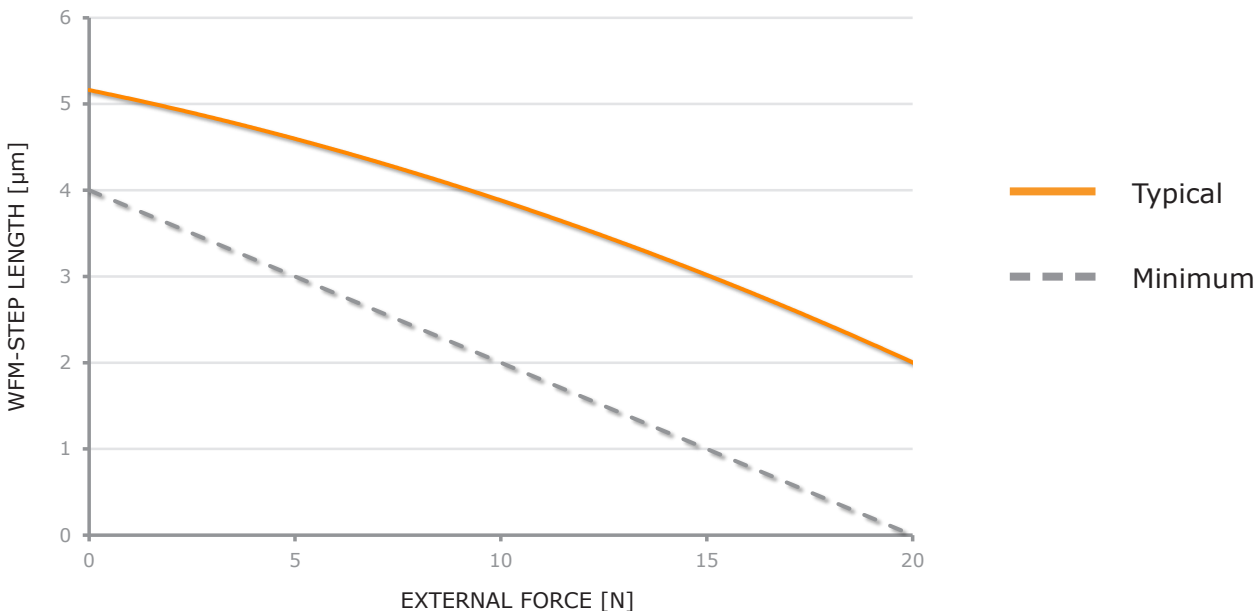
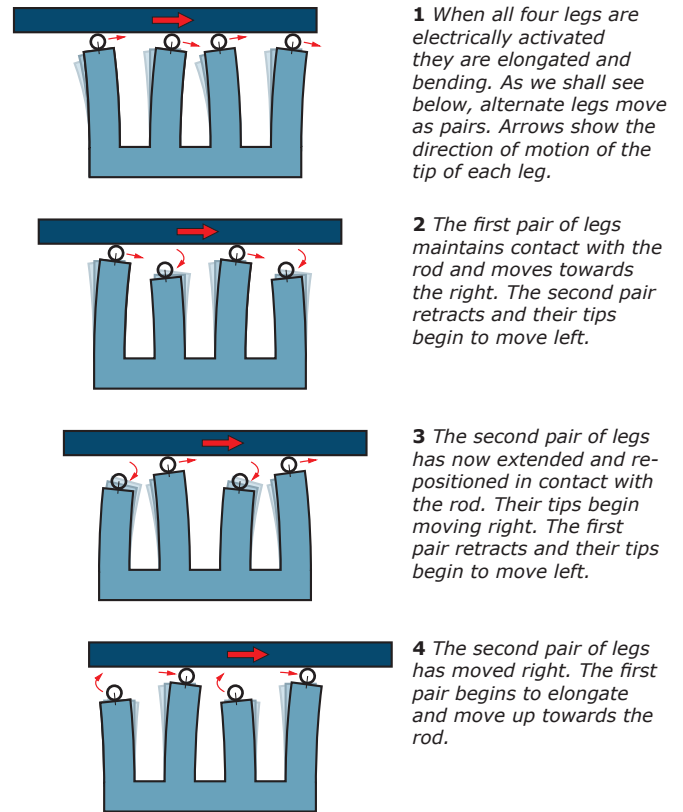
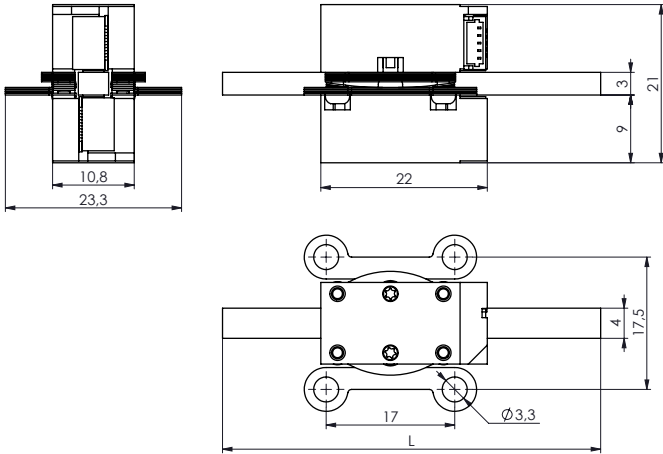

Figure 1 Typical motor performance with rhombic waveform (Rhomb S) at 650 Hz drive frequency. *Wfm-step* length is the average distance the drive rod moves when the legs take one step (i.e. for one waveform cycle). Using other waveforms than rhombic will give a different curve. Dotted line is guaranteed minimum for these drive conditions.

Main Dimensions LT2010A

Standard version



Main Dimensions LT2010B

Vacuum version

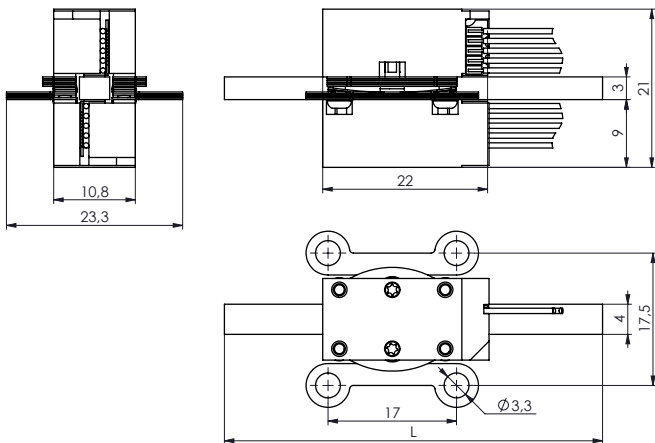

Note: Refer to drawings for details. Read *Installation Guidelines* carefully.

Electrical Connector Types

On motor type LT2010A (standard version) there are two connectors of type JST BM05B-SRSS-TB.

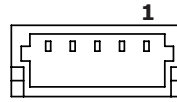

Motor type LT2010B (vacuum version) has soldered cables with two connectors of type JST 05SR-3S.



It is recommended to use a *Twin Connect Board* to have the two motor cables connected in parallel.

Pin Assignment

Pin	Terminal	Cable Color
1	Phase 1	Yellow
2	Phase 2	Green
3	Phase 3	White
4	Phase 4	Grey
5	Ground (GND)	Black or brown

Mechanical Adapter

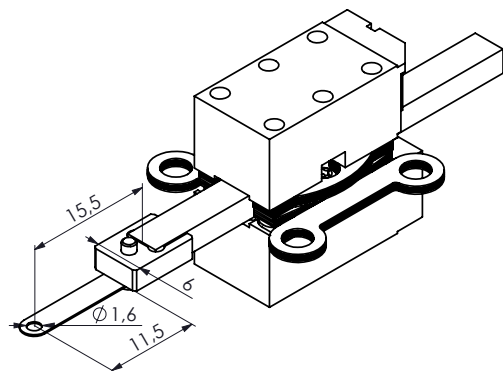

The drive rod can be fastened using a mechanical adapter with sheet metal extender. In this figure the adapter is mounted in front end of drive rod. Please read *Installation Guidelines* carefully for notes on how to properly connect the LEGS motor. Disregarding the instructions given in the guideline document may impair both motor performance as well as life time.

Technical Specification

Type	LT2010A (standard version)	LT2010B (vacuum version)	Unit	Note
Maximum Stroke	80 (L-20.8)	80 (L-20.8)	mm	100.8 mm drive rod, no mechanical adapter
Speed Range	0-10	0-10	mm/s	recommended, no load
Step Length	0.001 ^a -4	0.001 ^a -4	µm	no load, microsteps up to full wfm-steps
Resolution ^a	< 1	< 1	nm	
Recommended Operating Range	0-10	0-10	N	for best microstepping performance and life time
Stall Force	20	20	N	
Holding Force	22	22	N	
Vacuum	-	10 ⁻⁷	torr	
Maximum Voltage	48	48	V	
Connector	2 x JST BM05B-SRSS-TB	soldered cable with 2 x JST 05SR-3S		
Mechanical Size	22 x 21 x 10.8	22 x 21 x 10.8	mm	see drawing for details
Material in Motor Housing	Stainless Steel	Stainless Steel		
Weight	29	29	gram	approximate
Operating Temp.	-20 to +70	-20 to +70	°C	

a. Driver dependant

Item no.

LT2010 -

Stall Force

20 = 20 N

Version**Motor type**

A = SS / Stainless Steel

B = SSV / Stainless Steel Vacuum

Drive rod (standard lengths)

030 = 30 mm

060 = 60 mm

040 = 40 mm

070 = 70 mm

050 = 50 mm

101 = 100.8 mm

Mechanical adapter

A0 = No adapter

D1 = One adapter - Front

D2 = One adapter - Back

E1 = Two adapters - Front and back

Connector

A = JST connectors - for motor type A

B = Teflon cables PTFE AWG28 with JST connectors - for motor type B

Cable Options

00 = No cables (JST connectors only) - for motor type A

05 = 2 x 0.5 m - for motor type A

10 = 2 x 1.0 m - for motor type B

15 = 2 x 1.5 m - for motor type A

Twin connect board is sold separately, see accessory list on page 1.

Example:

LL2010A-050D1A05: LEGS Linear, 20N, version 10, stainless steel, 50 mm drive rod, one mechanical adapter front end, JST connector with 0.5 m cable

Note: All specifications are subject to change without notice.

Note: All combinations are **not** possible!Visit our website for application examples,
CAD files, videos and more...www.piezomotor.com

PiezoMotor Uppsala AB
Stålgatan 14
SE-754 50 Uppsala, Sweden

Telephone: +46 18 489 5000
Fax: +46 18 489 5001

info@piezomotor.com
www.piezomotor.com

